

## TABLE OF CONTENTS

Article 1. <b>INTRODUCTION</b>	<b>1-1</b>
Section 1.01 Authority.	1-1
Section 1.02 Purpose and intent.	1-1
Section 1.03 Title.	1-1
Article. 2. <b>DEFINITIONS</b>	<b>2-1</b>
Section 2.01 General.	2-1
Section 2.02 Accessory building or structure.	2-1
Section 2.03 Accessory use.	2-1
Section 2.04 Agricultural.	2-1
Section 2.05 Alley.	2-1
Section 2.06 Automobile service body shop.	2-1
Section 2.07 Automobile or trailer sales area.	2-2
Section 2.08 Automobile service station.	2-2
Section 2.09 Basement or cellar.	2-2
Section 2.10 Billboard or sign board.	2-2
Section 2.11 Boarding or lodging house.	2-2
Section 2.12 Breezeway.	2-2
Section 2.13 Building.	2-2
Section 2.14 Building height.	2-2
Section 2.14.1 Child care center.	2-3
Section 2.14.2 Child care home.	2-3
Section 2.15 Dwelling.	2-3
Section 2.16 Family.	2-3
Section 2.17 Farm.	2-3
Section 2.18 Floor area residential.	2-3
Section 2.19 Garage-private.	2-3
Section 2.20 Garage-commercial.	2-4
Section 2.21 Home occupation.	2-4
Section 2.22 Intensive farm.	2-4
Section 2.23 Junk.	2-4
Section 2.23.1 Junk Vehicle	2-4
Section 2.24 Junkyard.	2-5
Section 2.25 Kennel.	2-5
Section 2.26 Livestock.	2-5
Section 2.27 Lot.	2-5
Section 2.28 Lot area.	2-5
Section 2.29 Lot corner.	2-5
Section 2.30 Lot depth.	2-5
Section 2.31 Lot interior.	2-5
Section 2.32 Lot line.	2-6
Section 2.33 Lot, front line.	2-6
Section 2.34 Lot, rear line.	2-6
Section 2.35 Lot, side line.	2-6
Section 2.36 Lot width.	2-6
Section 2.37 Lot of record.	2-6

Section 2.38	Mobile home.	2-6
Section 2.39	Motel or hotel.	2-6
Section 2.40	Nonconforming structure.	2-6
Section 2.41	Nonconforming use.	2-7
Section 2.42	Nuisance.	2-7
Section 2.43	Parking area-private.	2-7
Section 2.44	Parking area-commercial.	2-7
Section 2.45	Parking space.	2-7
Section 2.46	Principal structure.	2-7
Section 2.47	Principal use.	2-7
Section 2.47.1	Roadside stand.	2-7
Section 2.48	Set-back.	2-8
Section 2.48.1	Shipping/Storage Container	2-8
Section 2.49	Sign.	2-8
Section 2.49.1	Social Event Venue.	2-8
Section 2.50	Special use.	2-8
Section 2.51.1	State licensed residential facility.	2-8
Section 2.51	Stock nurseries.	2-9
Section 2.52	Story.	2-8
Section 2.53	Street.	2-8
Section 2.54	Substandard lot.	2-9
Section 2.55	Subterranean or underground dwellings.	2-9
Section 2.55.1	Swimming Pool.	2-9
Section 2.56	Travel trailers or recreational vehicles.	2-9
Section 2.57	Variance.	2-9
Section 2.58	Yard-front.	2-10
Section 2.59	Yard-rear.	2-10
Section 2.60	Yard-side.	2-10
Section 2.61	Yard-Front-side.	2-10

Article 3. **GENERAL PROVISIONS**

**3-1**

Section 3.01	Compliance.	3-1
Section 3.02	Permit required.	3-1
Section 3.03	Certificate of occupancy.	3-1
Section 3.04	Access.	3-2
Section 3.05	Size of dwelling.	3-2
Section 3.06	Substandard lots of record.	3-2
Section 3.07	Moving of houses, buildings and structures.	3-2
Section 3.08	Subterranean or underground dwellings.	3-3
Section 3.09	Use of travel trailers or recreational vehicles.	3-3
Section 3.10	Mobile home.	3-3
Section 3.11	Home occupations.	3-5
Section 3.12	Land uses prohibited.	3-5
Section 3.13	Area requirements.	3-6
Section 3.14	More than one principal building on a lot.	3-6
Section 3.15	Rear dwellings.	3-6
Section 3.15.1	Temporary dwellings and buildings	3-6
Section 3.16	Visibility, fence regulations.	3-6

Section 3.17	Zoning ordinance application, Township exception.	3-7
Section 3.18	Basement quarters.	3-7
Section 3.19	Private roads and private driveways.	3-7
Section 3.20	Lot splits.	3-10
Section 3.21	Signs and billboards.	3-10
Section 3.22	Keeping of pets, animals and livestock.	3-16
Section 3.23	Open space preservation developments.	3-17
Section 3.24	Wind energy systems	3-22
Section 3.25	Junk Vehicle Ordinance	3-42
Section 3.26	Swimming Pool.	3-43
Section 3.27	Conditional Rezoning	3-44
Section 3.28	Large Solar Energy Systems	3-48
Section 3.29	Farm Labor Housing	3-56
Article 4.	<b>GENERAL ENVIRONMENTAL PROVISIONS</b>	<b>4-1</b>
Section 4.01	Drainage courses.	4-1
Section 4.02	Sand and gravel mining and related land use.	4-1
Section 4.03	Flood hazard zone.	4-4
Article 5.	<b>ZONING DISTRICTS AND MAP</b>	<b>5-1</b>
Section 5.01	Zoning Districts.	5-1
Section 5.02	Zoning district map.	5-1
Section 5.03	Resolution of zoning district boundaries.	5-1
Article 6.	<b>SINGLE FAMILY RESIDENTIAL DISTRICT (R-1)</b>	<b>6-1</b>
Section 6.01	Purpose.	6-1
Section 6.02	Principal uses permitted.	6-1
Section 6.03	Special permit uses.	6-1
Section 6.04	Accessory uses.	6-1
Section 6.05	Additional requirements.	6-2
Article 7.	<b>RESIDENTIAL/AGRICULTURAL DISTRICT (R-2)</b>	<b>7-1</b>
Section 7.01	Description of district.	7-1
Section 7.02	Principal uses permitted.	7-1
Section 7.03	Special permit uses.	7-1
Section 7.04	Accessory uses.	7-2
Section 7.05	Additional requirements.	7-2
Article 7A.	<b>RESIDENTIAL-ESTATE DISTRICT (R-3)</b>	<b>7A-1</b>
Section 7A.01	Purpose.	7A-1
Section 7A.02	Principal uses permitted.	7A-1
Section 7A.03	Special permit uses.	7A-1
Section 7A.04	Accessory uses.	7A-1
Section 7A.05	Additional requirements.	7A-1
Article 8.	<b>PLANNED UNIT RESIDENTIAL DISTRICT (PURD)</b>	<b>8-1</b>
Section 8.01	Purpose.	8-1
Section 8.02	Principal uses permitted.	8-1

Section 8.03	Special permit uses.	8-1
Section 8.04	Accessory uses.	8-1
Section 8.05	Additional requirements.	8-1
Article 9.	<b>EXCLUSIVE AGRICULTURAL (A-1)</b>	<b>9-1</b>
Section 9.01	Purpose.	9-1
Section 9.02	Principal uses permitted.	9-1
Section 9.03	Special permit uses.	9-1
Section 9.04	Accessory uses.	9-2
Section 9.05	Additional requirements.	9-2
Article 10.	<b>INTENSIVE AGRICULTURAL (A-2)</b>	<b>10-1</b>
Section 10.01	Purpose.	10-1
Section 10.02	Principal uses permitted.	10-1
Section 10.03	Special permit uses.	10-1
Section 10.04	Application for special permit use.	10-1
Section 10.05	Standards.	10-1
Article 11.	<b>AGRICULTURAL, INDUSTRY/BUSINESS (A-3)</b>	<b>11-1</b>
Section 11.01	Purpose.	11-1
Section 11.02	Principal uses permitted.	11-1
Section 11.03	Special permit uses.	11-2
Article 12.	<b>COMMERCIAL DISTRICT (C-1)</b>	<b>12-1</b>
Section 12.01	Purpose.	12-1
Section 12.02	Principal uses permitted.	12-1
Section 12.03	Special permit uses.	12-2
Section 12.04	Accessory uses permitted.	12-2
Section 12.05	Additional requirements.	12-2
Article 13.	<b>INDUSTRIAL DISTRICT (I-1)</b>	<b>13-1</b>
Section 13.01	Purpose.	13-1
Section 13.02	Principal uses permitted.	13-1
Section 13.03	Specific use requirements.	13-1
Section 13.03A.	Special permit uses.	13-2
Section 13.04	Accessory uses permitted.	13-2
Section 13.05	Additional requirements.	13-2
Article 14.	<b>ACCESSORY USE PROVISIONS</b>	<b>14-1</b>
Section 14.01	Accessory buildings.	14-1
Section 14.02	Accessory vehicle storage.	14-3
Article 15.	<b>NONCONFORMING USES, LOTS AND STRUCTURES</b>	<b>15-1</b>
Section 15.01	Intent.	15-1
Section 15.02	Nonconforming lots.	15-1
Section 15.03	Nonconforming uses of land.	15-1
Section 15.04	Nonconforming structures.	15-2
Section 15.05	Nonconforming uses of structures and land.	15-2

Section 15.06	Repair and maintenance of nonconforming uses.	15-2
Article 16.	<b>TABLE OF DISTRICTS STANDARDS/REGULATIONS</b>	<b>16-1</b>
Section 16.01	Footnotes to schedule of regulations.	16-2
Section 16.02	Standards for residential-estate (R-3).	16-3
Article 17.	<b>SPECIAL LAND USE PERMITS</b>	<b>17-1</b>
Section 17.01	Purpose.	17-1
Section 17.02	Procedures for making application.	17-1
Section 17.03	Required in application.	17-1
Section 17.04	Additional information and waiver.	17-2
Section 17.05	Procedure for review and findings-public hearings.	17-2
Section 17.06	General standards for making determinations.	17-2
Section 17.07	Conditions and safeguards; termination.	17-3
Section 17.08	Recommendation to Township Board.	17-4
Section 17.09	Township Board; issuance/denial of special permit.	17-4
Section 17.10	Decision.	17-4
Section 17.11	Modification of approved special use permit plan.	17-4
Section 17.12	Appeals and questions of interpretation of ordinance.	17-4
Article 18.	<b>SPECIAL USE STANDARDS AND REGULATIONS</b>	<b>18-1</b>
Section 18.01	Scope, purpose and intent.	18-1
Section 18.02	Animal hospitals/clinics.	18-1
Section 18.03	Auto service body shops and commercial garages.	18-1
Section 18.04	Automobile service stations.	18-2
Section 18.05	Commercial TV, radio tower, public utility towers.	18-3
Section 18.05A	Wireless communication facilities.	18-4
Section 18.06	Farms and animals.	18-13
Section 18.07	Horseback riding stables.	18-13
Section 18.08	Private parks/winter sports area.	18-14
Section 18.09	Shooting ranges, gun and skeet clubs.	18-14
Section 18.10	Kennels, conditions regarding.	18-15
Section 18.11	Commercial campgrounds.	18-16
Section 18.12	Group child care home and child care center.	18-17
Section 18.13	State licensed residential group facilities.	18-18
Section 18.14	Social Event Venue	18.19
Article 19.	<b>SITE PLAN REVIEW STANDARDS</b>	<b>19-1</b>
Section 19.01	Scope, purpose and intent.	19-1
Section 19.02	Site plan review procedure.	19-1
Section 19.03	Standards for site plan approval.	19-2
Section 19.04	Site plan, water and drainage standards.	19-3
Section 19.05	Conditions and plan approval.	19-4
Article 20.	<b>ADMINISTRATION</b>	<b>20-1</b>
Section 20.01	Zoning Administrator; designation.	20-1
Section 20.02	Zoning Administrator(s); duties.	20-1

Section 20.03	Zoning Administrator(s); powers.	20-1
Section 20.04	Board of Appeals; members; appointment.	20-1
Section 20.05	Terms.	20-2
Section 20.06	Board of Appeals; compensation.	20-2
Section 20.07	Board of Appeals; officers.	20-2
Section 20.08	Board of Appeals; powers.	20-2
Section 20.09	Variances.	20-3
Section 20.10	Publication and delivery of notice of public hearing.	20-6
<b>Article 21.</b>	<b>AMENDMENTS</b>	<b>21-1</b>
Section 21.01	Governing provisions.	21-1
Section 21.02	Initiation.	21-1
Section 21.03	Referral to planning commission.	21-1
Section 21.04	Filing; publications.	21-1
Section 21.05	Hearing.	21-1
<b>Article 22.</b>	<b>FEES, CHARGES, AND EXPENSES</b>	<b>22-1</b>
Section 22.01	Schedule of fees.	22-1
<b>Article 23.</b>	<b>VIOLATIONS AND PENALTIES</b>	<b>23-1</b>
Section 23.01	General.	23-1
Section 23.02	Violation and penalty.	23-1
<b>Article 24.</b>	<b>SEVERABILITY</b>	<b>24-1</b>
Section 24.01	Provisions severable.	24-1
<b>Article 25.</b>	<b>REPEAL OF CONFLICTING ORDINANCES</b>	<b>24-1</b>
Section 25.01	Repeal; adoption.	



## ARTICLE 2

### 110.200 DEFINITIONS

#### 110.201 General

Section 2.01. As used in this Ordinance, certain words or phrases shall be interpreted in the following manner. Words commonly used in the singular number shall include the plural and words used in the plural include the singular. The word “shall” is mandatory and directory. The word “may” is discretionary and is not interchangeable with the word “shall”. The word “building” includes the word “structure” and visa versa. Terms not defined in this section shall have the meanings customarily assigned to them.

#### 110.202 Accessory building or structure.

Section 2.02. Accessory building or structure shall mean a building or structure or a portion of a building or structure subordinate to and on the same lot as the main building and occupied by or devoted exclusively to an accessory use, including, but not limited to, a private garage.

#### 110.203 Accessory use.

Section 2.03. A use naturally and normally incidental and subordinate to the principal use of the main building or lot.

#### 110.204 Agricultural.

Section 2.04. Substantially undeveloped land devoted to the production of plants and animals useful to man, including forages; grains and feed crops; dairy and dairy products; livestock, including breeding and grazing; fruits; vegetables; and other similar uses and activities.

#### 110.205 Alley.

Section 2.05. A public way not more than twenty (20) feet wide which affords only a secondary means of access to abutting property and which is not intended for general traffic circulation.

#### 110.206 Automobile service body shop.

Section 2.06. A facility providing general repair, rebuilding or reconditioning of engines, motor vehicles or trailers; collision service including body frame or fender straightening or repair; overall painting or paint shop; or vehicle steam cleaning. A facility providing minor repairs such as incidental body and fender work, painting and upholstering, replacement of parts and motor service to passenger automobiles and trucks not exceeding one and one-half (1 ½) tons capacity shall not be considered an automobile body shop under this section. (See Section 2.20).

**110.207 Automobile or trailer sales area.**

Section 2.07. An open area other than a street used for the display, sale or rental of new or used motor vehicles or trailers and where no repair work is performed.

**110.208 Automobile service station or filling station.**

Section 2.08. A place where gasoline, kerosene or any other motor fuel or lubrication oil or grease for operating motor vehicles is offered for sale to the public and deliveries are made directly into motor vehicles, including greasing and oiling on the premises.

**110.209 Basement or cellar.**

Section 2.09. A story having more than one-half (1/2) of its height or more than one-half (1/2) of its circumference below the average grade of the established final adjoining ground within ten (10) feet of the perimeter of the building. A basement or cellar shall not be counted as a story for purposes of height measurement.

**110.210 Billboard or sign board.**

Section 2.10. Any structure or portion thereof situated on private premises on which lettered, figured, or pictorial matter is displayed for informational or advertising purposes.

**110.211 Boarding or lodging house**

Section 2.11. A building, or part thereof, other than a hotel or restaurant, where meals and/or lodging are provided for two or more persons, not transients, for compensation.

**110.212 Breezeway.**

Section 2.12. A covered structure connecting an accessory building with the principal building or structure.

**110.213 Building.**

Section 2.13. Any structure having a roof supported by columns or walls, including a mobile home or mobile structure, a premanufactured or pre-cut structure, above or below ground, designed primarily for the shelter, support or enclosure of persons, animals or property of any kind.

**110.214 Building height.**

Section 2.14. The vertical distance measured from the established grade to the highest point in the roof surface for flat roofs; to the deck line of mansard roofs; and to the average height between eaves and ridge for gable, hip, and gambrel roofs.

**110.215 Dwelling.**

Section 2.15. A building or portion thereof designed and used exclusively as the residence or sleeping place for one or more persons, including one family, two family and multiple family dwellings, apartment/motels, hotels, boarding, and lodging houses and meeting all applicable code provisions in effect on the date of construction. This definition shall include all mobile homes and other prefabricated and/or pre-assembled units used for those purposes as described in this section.

**110.216 Family.**

Section 2.16. Any number of individuals living and cooking together on the premises as a single housekeeping unit and whose relationship is of a continuing non-transient domestic character.

**110.217 Farm.**

Section 2.17. All properties under one ownership which may or may not be contiguous, upon which agricultural activities are undertaken on a commercial basis.

**110.218 Floor area residential.**

Section 2.18. The area of all floors computed by measuring the dimensions of the outside walls of the building. Porches, patios, terraces, breezeways, car ports, verandas, garages, unfinished attics and attic floor areas with less than five vertical feet from floor to finished ceiling are excluded from computation under this definition. Basements, the walls of which are fifty (50%) percent or less below grade may be included in computing floor area.

**110.219 Garage – private.**

Section 2.19. An accessory building, attached to or detached from a residential structure, or a portion of a residential structure used only for the storage of self propelled passenger vehicles, trucks, trailers or any other personal property belonging to the occupants of the premises.

**110.220 Garage – commercial.**

Section 2.20. A structure or portion thereof other than a private or municipal garage used for the storage, sale, hire or minor repair of self propelled vehicles or trailers. Minor repairs shall include incidental body and fender work, painting and upholstering, replacement of parts and motor service to passenger automobiles and trucks. (Also See Section 2.06)

**110.221 Home occupation.**

Section 2.21. An accessory use of a dwelling unit for gainful employment conducted by members of the family only, within its place of residence, provided that the space used is incidental to residential use and requires only minor internal or external structural alterations, and that no articles are sold or offered for sale except such as are produced by such home occupation. All home occupations shall be subject to the provision of Article 3, Section 3.11.

**110.222 Intensive farm.**

Section 2.22. Agricultural operations which are likely to negatively influence non-agricultural uses through the emission of noise, odors, or potential groundwater contamination, such as but not limited to confined feeding of livestock.

**110.223 Junk.**

Section 2.23. For purposes of this Ordinance, “junk” shall be defined as including a discard of items which are not normally associated with residential usage including older scrap copper, iron, steel, brass, rope, rags, batteries, paper, rubber debris, waste, discarded household appliances, dismantled vehicles or parts thereof, and other such items as shall constitute health or safety hazards or menace to persons whether the same have value for reuse or resale after original use.

**110.224 Junkyard.**

Section 2.24. For purposes of this Ordinance, “junkyard” shall be defined as any place or location used for the purposes of dismantling, wrecking, disposing of or storing the refuse of automobiles or their parts or for the storage of junk as defined in Section 2.23 above.

**110.225 Kennel.**

Section 2.25. Any premises on which three (3) or more dogs, cats, or like fur bearing animals, four (4) months old or older are kept.

**110.226 Livestock.**

Section 2.26. Horses, or any animal which is raised for the production of food for human consumption or for the production of fiber. Not to include dogs, snakes, or vicious animals.

**110.227 Lot.**

Section 2.27. Land occupied or to be occupied by a building and its accessory buildings, or by a dwelling group and its accessory buildings, together with such open spaces as are required under the provisions of this ordinance for a lot in the district in which such lot is situated and having the required frontage on a street.

**110.228 Lot area.**

Section 2.28. The computed area inside of the lot lines.

**110.229 Lot corner.**

Section 2.29. A lot in which at least two adjacent sides abut for full length upon a street, provided that the interior angle at the intersection of such two sides is less than one hundred thirty five (135) degrees.

**100.230 Lot depth.**

Section 2.30. The mean horizontal difference between the front and rear lot lines measured in the direction of the side parcel lines.

**110.231 Lot interior.**

Section 2.31. A lot other than a corner lot.

**110.232 Lot line.**

Section 2.32. The property lines bounding the lot line.

**110.233 Lot front line.**

Section 2.33. In the case of a lot abutting upon only one street, it shall mean the line separating such lot from such street, even if the street is only as easement. In the case of a lot abutting on only one street and abutting upon a lake or river, the front lot line shall be the high water mark as it abuts upon the lot.

**110.234 Lot, rear line.**

Section 2.34. That line which is opposite from the front lot line.

**110.235 Lot, side line.**

Section 2.35. Any lot line not qualified as a front or rear lot line.

**110.236 Lot width.**

Section 2.36. The mean horizontal distance across the lot between lot side lines.

**110.237 Lot of record.**

Section 2.37. A lot which is a part of a subdivision and is shown on a plat or map thereof which has been recorded in the Office of the Register of Deeds for Muskegon County, or a parcel of land described by survey or metes and bounds which is the subject of a deed or land contract recorded in said office prior to the date of enactment of this Ordinance.

**110.238 Mobile home.**

Section 2.38. Mobile home means a structure, transportable in one or more sections, which is build on a permanent chassis and designed to be used as a dwelling with or without permanent foundation, when connected to the required utilities.

**110.239 Motel or hotel.**

Section 2.39. A series of attached, semi-detached or detached rental units containing a bedroom, bathroom, closet space and, where permitted, kitchenettes, as regulated in this Ordinance.

**110.240 Nonconforming structure.**

Section 2.40. A structure lawfully existing at the time of the effective date of this Ordinance, and which does not conform with the regulations of the district in which it is thereafter located.

**110.241 Nonconforming use.**

Section 2.41. The lawful use of a structure or land at the time of the effective date of this Ordinance which does not conform with the regulations of the district in which it is thereafter located.

**110.242 Nuisance.**

Section 2.42. An offensive, annoying, unpleasant or obnoxious thing or practice. A cause or source of annoyance, especially a continuing or repeated invasion of any physical characteristics or activity or use across the property line which can be perceived by or which affects human beings.

The generation of an excessive or concentrated movement of people or things such as, but not limited to: (a) noise, (b) dust, (c) smoke, (d) odor, (e) glare, (f) fumes, (g) flashes, (h) vibration, (i) shock waves, (j) heat, (k) electronic or atomic radiation, (l) objectionable effluent, (m) noise of a congregation of people, particularly at night, (n) passenger and truck traffic, (o) invasion of nonabutting street frontage by traffic and vicious animals.

**110.243 Parking area – private.**

Section 2.43. An open area for the same uses as a private garage.

**110.244 Parking area – commercial.**

Section 2.44. An open area, other than a street or other public way, used for the parking of automobiles and available for public use, whether for a fee, free or as an accommodation for clients or customers of a commercial use.

**110.245 Parking space.**

Section 2.45. The area required for parking one automobile, which in this Ordinance shall be an area ten (10) feet wide and twenty (20) feet long not including drive or passage ways.

**110.246 Principal structure.**

Section 2.46. The main building on a lot including, but not limited to, residential, commercial, institutional structures and mobile homes.

**110.247 Principal use.**

Section 2.47. That use of land or building that constitutes the primary use of the lot as permitted as a principal use under this Ordinance.

**110.248 Set-back.**

Section 2.48. The minimum horizontal distance between the front line of a building, including steps and unenclosed porches, and the street line exclusive of the public road right of way, or the high water mark where the high water mark is used as the front lot line.

**110.249 Sign.**

Section 2.49. The name, identification, description, display or illustration which is affixed to or painted or represented directly or indirectly upon a building, structure or piece of land, and which directs attention to an object, product, place, activity, person, institution, or organization or business, and including those signs described in Section 2.10.

**110.250 Special use.**

Section 2.50. A use of such a special nature as to make impractical its predetermination as a principal use in a district. Such uses shall be subject to permit procedures and standards set forth in this Ordinance.

**110.251 Stock nurseries.**

Section 2.51. An establishment for the commercial production of trees and/or shrubs until they are ready for sale and transplantation.

**110.252 Story**

Section 2.52. That portion of a building, other than a cellar or mezzanine, included between the surface of any floor and the surface of the floor next above it; or, if there is no floor above it, then the space between the floor and ceiling.

**110.253 Street.**

Section 2.53. A public or private way, square or lane, permanently open to common and general use, other than an alley, which affords the principal means of access to abutting property.

**110.254 Substandard lot.**

Section 2.54. A lot of record or a lot which is described in a land contract or deed executed and delivered before the adoption of this Ordinance which does not meet the requirements of the Ordinance for lot area. (See Section 2.37).

**110.255 Subterranean or underground dwellings.**

Section 2.55. A dwelling that is partially or wholly surrounded by earth on no more than three (3) sides and the roof, and which is to be used as an occupied dwelling according to the district regulations.

**110.256 Travel trailers or recreational vehicles.**

Section 2.56. Any vehicle which is usually portable and capable of being connected to utilities, normally used for vacation or recreational purposes, and is either motor driven or trailered, such as, but not limited to, motor homes, campers, camper trailers, off-road vehicles, boats and utility trailers.

**110.257 Variance.**

Section 2.57. A grant of relief to a person from the dimensional requirements of this Ordinance.

**110.258 Yard – front.**

Section 2.58. An open space extending the full width of the lot between the principal building and the front lot line.

**110.259 Yard – rear.**

Section 2.59. An open, unoccupied space, except by a building of accessory use as permitted, extending for the full width of the lot between rear line of the principal building and the rear lot line.

**110.260 Yard – side.**

Section 2.60. An open, unoccupied space situated between the side line of the principal building and the side line of the adjacent lot and extending from the front yard to the rear yard.



**110.303 Certificate of occupancy.**

Section 3.03. After having obtained the required permits and complying with the requirements contained in this Ordinance, the Administrator of this Ordinance shall issue a certificate of occupancy to the applicant. A building or structure shall not be used or occupied prior to the issuance of such a certificate.

**110.304 Access.**

Section 3.04. An application for a land use permit shall be denied unless the applicant can satisfactorily demonstrate that the property for which the permit is requested has adequate access. Adequate access, for purposes of this Ordinance, shall mean property that fronts or abuts an improved street, a permanent recorded non-obstructed easement of access or right-of-way to a street of at least 20 feet in width.

**110.305 Size of dwelling.**

Section 3.05. No building to be used as a dwelling shall hereafter be erected or altered having a floor area of less than that required by the Zoning District Standards.

**110.306 Substandard lots of record.**

Any lot in a single ownership which ownership was of record at the time of the adoption of this Ordinance that does not meet the requirements of this Ordinance for lot area, may be utilized for uses permitted under this Ordinance so long as the owner meets an adjusted requirement of sixty (60) percent of the minimum lot area requirement of the zoning district, or lot area is one (1) acre or greater. Further, the owner must meet the yard and setback requirements of the zoning district as otherwise designated and required by this Ordinance. If already less than the minimum required, no lot shall be further divided or reduced. [Ord. # 2020-03, effective 11/19/2020]

**110.307 Moving of houses, buildings, and structures.**

Section 3.07. No pre-existing home, building or structure shall be moved into the Township from a point outside the Township limits, or shall be moved from one location in the Township to some other different location until and unless the mover of the home, building or structure submits a site plan for review, the site plan shall show the approximate final position of the home, building or structure at the proposed new location. The site and moving plan shall be submitted and reviewed before the mover may receive a moving permit for the Administrator.

The Administrator shall issue a permit approving the transfer after having determined that adequate on-site facilities exist such as water, gas, sewer and electricity, or that such utilities are available and will be installed or otherwise be made operable within six months of the transfer of the house, building or structure to its new location. The Administrator shall further determine that prior to the moving of the house, building or structure and after inspection, the house, building or structure will

comply or will be brought into compliance with the applicable building code then in force within the township.

The Administrator must further determine that a certain time has been specified during which the move will take place, that the streets that will be used during the process of moving the house, building or structure have been specified and their use approved, and that adequate provisions have been made to insure the safe transportation of the home, building or structure, including the use of escort vehicles as required by the County Sheriff's Department, to proceed and to follow the house, building or structure during the actual move. The home, building or structure must comply with all pertinent local, State and Federal regulations regarding zoning, construction and installation in effect at the time of application.

**110.308 Subterranean or underground dwellings.**

Section 3.08. No subterranean dwelling as defined in Section 2.55 [Section 110.225] may be constructed unless it complies with the following provisions:

- a. It shall meet all zoning, building, county and State Health Code requirements;
- b. The design shall be certified by a registered architect or engineer;
- c. The roof structure and truss work must be designed and certified by a registered architect or engineer;
- d. Yard dimensions shall exclude any portion of ground which is covering a portion of the dwelling;
- e. No land use permit shall be issued where, in the opinion of the Administrator, such site is unsuitable due to a reasonable danger of flooding from surface or subterranean sources or is likely to be situated on a site which has a reasonable likelihood of erosion.

**110.309 Use of travel trailers or recreational vehicles.**

Section 3.09. No person shall use any travel trailer or recreational vehicle outside of a licensed mobile home park or trailer coach park for camping purposes except as provided in this Ordinance. Such uses shall be limited to 30 days cumulative use in a calendar year in residential districts where such use is on a lot on which there is located a permanent occupied dwelling or 105 days cumulative use in a calendar year on lots located in an agricultural district.

Travel trailers and recreational vehicles, when located outside of State licensed trailer coach parks, shall be removed from all lots during periods in which they are not being used for camping or recreational purposes and are otherwise unoccupied except where the travel trailer or recreational vehicle is stored.

Each occupied travel trailer or recreational vehicle shall be self-contained. No waste water from travel trailers, recreational vehicles or any other sources shall be deposited on the surface of the ground, if surface waters, or underground in the Township and all such vehicle owners and users shall specifically act in accordance with all rules and regulations of the Muskegon County Health Department and all other laws of the State of Michigan.

**110.310 Single Family Dwellings.**

Any single-family dwelling erected on site, or a manufactured dwelling constructed at an off-site location which is not located within a manufactured home park, shall be permitted in the Agricultural and Residential Zoning Districts only if in conformance with all of the following requirements:

- (a) The dwelling unit must conform to the minimum floor area, yard, and lot area requirements for the zoning districts in which it is located.
- (b) The minimum width of any single-family dwelling unit shall be twenty-four (24) feet for at least sixty-seven percent (67%) of its length, measured between the exterior parts of the walls having the greatest length.
- (c) In the case of a manufactured home, proof must be submitted that the manufactured home is either:
  - (1) New and certified by the manufacturer and/or appropriate inspection agency as meeting the Manufactured Home Construction and Safety Standards of the Department of Housing and Urban Development, as amended, or any similar successor or replacement standards which may be promulgated, or
  - (2) Used and certified by the manufacturer and/or appropriate inspection agency as meeting the standards referenced above.

- (d) The dwelling shall comply with all building, electrical, plumbing, fire, energy, and other similar codes of the Township. Where a dwelling is required by law to comply with any federal or state standards or regulations for constructions, and where such standards or regulations for construction are different than those imposed by Township codes, then and in such event such federal or state standard or regulation shall apply. Appropriate evidence of compliance with such standards or regulations shall be provided to the Township Building Inspector.
- (e) The dwelling shall be firmly attached to a permanent continuous foundation with frost-protected footings constructed on the building site, such foundation to have a wall to be constructed of such materials and type as required by the Township Building Code for on-site constructed single-family dwellings. If the dwelling is a manufactured home, its foundation shall hide the chassis, undercarriage, and towing mechanism.
- (f) If the dwelling is a manufactured home, the manufactured home shall be installed pursuant to the manufacturer's setup instructions and shall be secured to the building site by an anchoring system or device complying with the rules and regulations, as amended, of the Michigan Manufactured Home Commission. The wheels of the manufactured home shall be removed.
- (g) All dwellings without basements, except slab on grade construction, shall provide a crawl space below the entire floor of the dwelling four feet in depth, with a vapor barrier consisting of two inches of concrete on the floor of the crawl space. The crawl space shall also be provided with adequate drains to drain any accumulation of water in the crawl space. The building inspector may allow an alternative building plan to be utilized if consistent with the approved construction code of the Township.
- (h) All dwellings shall be connected to a septic or sewer system and a water supply system approved by the County Health Department.
- (i) The dwelling shall be constructed with construction materials of consistent quality. Additions of rooms or other areas shall be constructed with similar workmanship as the original structure. Permanent attachment to the principal structure shall include construction of a foundation and no addition shall involve placing a bearing load on a manufactured home. Hybrid construction combining on site constructed with off-site constructed dwellings or two or more different off-site constructed dwellings is prohibited.
- (j) The dwelling shall have no less than two (2) exterior doors, with the second one being in either the rear or the side of the dwelling.

- (k) A special temporary manufactured home or recreational vehicle permit may be issued for a period not to exceed one hundred eighty (180) days when the Applicant can demonstrate an intent to construct, reconstruct or rehabilitate structures or buildings located on the property. The original permit may be extended by the administrator for an additional one hundred eighty (180) days upon a showing that the Applicant has substantially progressed towards construction, reconstruction, or rehabilitation of the other structure or building. The total period of the temporary permit, including any extensions, shall not exceed three hundred sixty (360) days. In no case shall a temporary permit be issued unless the Applicant can further demonstrate that the Applicant has satisfied all Health Department requirements of a safe water supply and proper sewage disposal and treatment. [amended 2024-02, eff. 04/26/2024]

**110.311 Home occupations.**

Section 3.11. Occupations engaged in within a dwelling by the resident or residents of that dwelling are allowed if the same comply with all of the following conditions and limitations:

- a. Are operated in their entirety within the dwelling and not within any accessory building located upon the premises;
- b. Are only conducted by the person or persons occupying the premises as the principal residents. No person shall provide services or be employed in connection with the home occupation except those family members residing on the premises;
- c. The dwelling has no exterior evidence other than a permitted sign to indicate that the same is being used for any purpose other than that of a dwelling;
- d. The occupation conducted therein is clearly incidental and subordinate to the principal use of the premises for residential purposes. The space of the home occupation must not exceed more than 25 percent of the dwelling, excluding accessory buildings, regardless of the site of the home occupation;
- e. The Administrator shall have the authority to conduct an inspection of any home occupation in order to determine compliance with the requirements of this Section and upon making a determination that any home occupation does not comply, may serve a notice of termination on the property owner who shall then have a right of appeal to the Board of Appeals. Upon appeal to the Board of Appeals of such termination, it shall have the authority to determine whether or not a proposed use complies with the terms of the Ordinance and is within the spirit of the same to insure the compatibility of the use with the character of the zoning classification to which the same is located.

**110.312 Land uses prohibited.**

Section 3.12. No land may be used in such a manner as to cause air or water pollution, erosion or excessive noise, dust or obnoxious smell, water run-off

from property or in any other manner which creates a hazard to adjacent land, improvements or occupants. No future use different than the lawful use or a valid non-conforming use may be made of property unless specifically allowed by this Ordinance without first obtaining change of zoning or special use permit as may apply in the individual circumstances. Further, no tin cans, stoves, garbage, automobile bodies, junk, refuse or any waste material as defined in Article 2 shall be dumped or allowed to remain on any private or public land within the Township unless as otherwise provided in this Ordinance at such a location as has been designated sanitary land-fill or junk yard by the Township and County Health Department with necessary approval from the State of Michigan licensing agency responsible therefore.

**110.313 Area requirements.**

Section 3.13. No yard or lot existing at the time of the passage of this Ordinance shall be reduced in size or area below the minimum requirements set forth in this Ordinance. Yards or lots created after the effective date of this Ordinance shall meet at least the minimum requirements established by this Ordinance.

**110.314 More than one principal building on a lot.**

Section 3.14. Not more than one principal building shall be located on a lot in an R-1 district.

**110.315 Rear dwellings.**

Section 3.15. No building in addition to a main building on the same lot shall be used for residential purposes. Non-conforming lots containing more than one dwelling shall be made conforming where possible to all other yard and open space requirements of this Ordinance.

**110.315.1 TEMPORARY DWELLINGS AND BUILDINGS.**

Section 3.15.1. Temporary dwellings and buildings may be placed on a lot or parcel of record and occupied only under the following conditions:

- (a) A temporary land use permit agreement shall be filed with the Zoning Administrator prior to the placement of any temporary dwelling or building within the Township. Temporary land use permits shall authorize the placement of temporary dwellings or buildings for a maximum of one (1) year.

- (b) During renovation of a principal building damaged by fire or natural disaster, a temporary dwelling or building is authorized, however the temporary dwelling or building shall be removed when repair of damage is complete. In no case shall a temporary dwelling or building be located on the lot of parcel for more than thirty (30) days following issuance of the occupancy permit.
- (c) Temporary dwellings or buildings, including trailers, incidental to construction and land development work, are permitted, except that no temporary dwelling is permitted during construction of multiple family dwellings. Said temporary dwelling or building shall be removed from the lot or parcel within thirty (30) days of issuance of the occupancy permit for the principal dwelling.
- (d) A bond in the amount of five-hundred dollars (\$500) shall be required to insure removal of the temporary dwelling or building which has been used incidental to construction and land development work. The bond may be in the name of the applicant and Casnovia Township and may be maintained at the applicant's bank until released by the Township. A copy of the Certificates of the guarantee or bond shall be provided to the Zoning Administrator and shall be maintained with the permit agreement. A bond shall not be required for temporary dwellings used during renovation of a principal building damaged by fire or natural disaster. *[New section  
3.15.1 Ord. # 110-300, effective 6/5/1997]*

**110.316      Visibility, fence regulations.**

Section 3.16. At any intersection of public roads, no fence, structure, walls, scrubs, trees or plants shall be permitted within 20 feet of the right-of-way lines of the public highways which will obstruct the view of the users of the highways. No motor vehicles, house or tent trailers shall be stored or parked within 35 feet of the highway right-of-way line.

**110.317      Zoning ordinance application, Township exception.**

Section 3.17. The terms of this Ordinance shall not apply to lands, buildings, activities or uses of land or buildings if conducted by or on behalf of the Township in the performance of those activities required or allowed under the Michigan Constitution, State laws or Township ordinances.

**110.318      Basements as sleeping quarters**

Section 3.18. Sleeping quarters in basements shall be permitted only if there are two means of exit from said basement, one of which shall be a door leading directly to the outside of the basement and each room used as sleeping quarters has at least one window opening to the outside with a minimum area of 5.7 square feet and a minimum side dimension of 20 inches. Where two or more walls of a structure are above grade, and a least one access and egress to the out of doors as provided directly to the out of doors at grade level by a door, this structure shall not be classified as a basement.

**110.319 Private roads and private driveways.**

Private Roads and Private Driveways shall be subject to the following regulations:

- (a) No building or structure shall be built upon any lot which does not abut a public street except in compliance with the requirements of this section.
- (b) All private driveways, private roads and the lots to be served thereby shall comply with the requirements of the Casnovia Township Zoning Ordinance and the Subdivision Control Act of 1967 (MCLA 560.101 et seq.), as both may be amended from time to time.
- (c) Each private road shall extend from a public right-of-way to the lot(s) served thereby. A document describing the private road shall be recorded with the Muskegon County Register of Deeds and shall also be provided to the purchaser of any parcel served by a private road. The requirements for maintenance provisions for private roads shall be as follows:
  - (1) The Applicant(s)/owner(s) of a proposed private road right-of-way or private road shall also provide the Township, as condition of approval, with a private road maintenance or restrictive covenant agreement in such a form as to be recorded with the office of the Register of Deeds. It shall be signed by all the owner(s) of the easement or right-of-way of the private road and by any other parties having any interest therein. Any building(s) or parcel(s) thereafter created or constructed on the private road shall also be subject to the road maintenance or restrictive covenant agreement. Such agreement shall provide for and assure that the private road shall be regularly maintained, repaired and snow plowed so as to assure that the private road is safe for travel at all times. The agreement shall also provide for the payment of all costs and expenses of such maintenance, repair and snowplowing by all or any of the parties in interest.
  - (2) Maintenance, repair and liability for private roads shall be the responsibility of benefiting property owners with access to the private

road and not the responsibility or liability of the Township, Township staff or Township consultants used by the Township in the review and approval of private roads.

- (3) No construction permits shall be issued and no construction on a private road shall commence until the maintenance agreement has been reviewed and approved by the Township.
- (d) No private driveway shall serve more than one single family or duplex residential lot. For the purpose of this section, “duplex” is defined as a two-family dwelling located on a single lot in common ownership and sharing at least one common wall, ceiling, or fire separation assembly. In order to be properly protected by Casnovia Township Emergency Vehicles and personnel, private driveways shall be constructed and maintained as follows:

- (1) A driveway shall have a cleared width of twenty (20) feet.

- (2) The traveled portion of a driveway shall be twelve (12) feet wide and shall be constructed of six (6) inches of gravel or other suitable road building material, so as to provide sufficient integrity to allow the safe passage of emergency vehicles.

- (e) A private road is a right-of-way which serves more than one single family or duplex residential lot.

- (1) All private roads for single-family or two-family residential lots shall be located within an easement of sixty-six (66) foot width.

- (2) All private roads shall have a minimum clear improved passable area of twenty-two (22) feet in width. For the purpose of this section, “clear improved and passable area” shall mean that the area is cleared of all brush, shrubs, trees, roots, or other debris, and that it is level enough to permit a vehicle to travel within that area; “improved area” shall mean a surface which meets or exceeds the then current standards (at the time of construction) of both the Muskegon County Road Commission and Michigan Department of Transportation for an aggregate base course road. i.e., six (6) inches of packed gravel.

- (3) Land immediately adjacent to a private road shall be ditched along its entire length at a slope no greater than one (1) on three (3) for a front slope, and one (1) on two (2) for the ditches back slope. All ditches shall flow into a natural drainage course or a cross culvert beneath the private road. All culverts must be approved by the Muskegon County Road Commission.

- (4) The terminus of each private road shall contain a 100-foot easement for a cul-de-sac or 66-foot easement extending 10 foot in all directions from the edge of an alternate turnaround. Within the easement, a 96 foot cul-de-sac/60-foot Y/120-foot hammerhead is required as shown in the figure below. The center of a cul-de-sac need not be graveled or paved so long as it is the same grade as the road, maintains the cleared width, and the improved area (road bed) within the cul-de-sac maintains the minimum 22-foot width required.

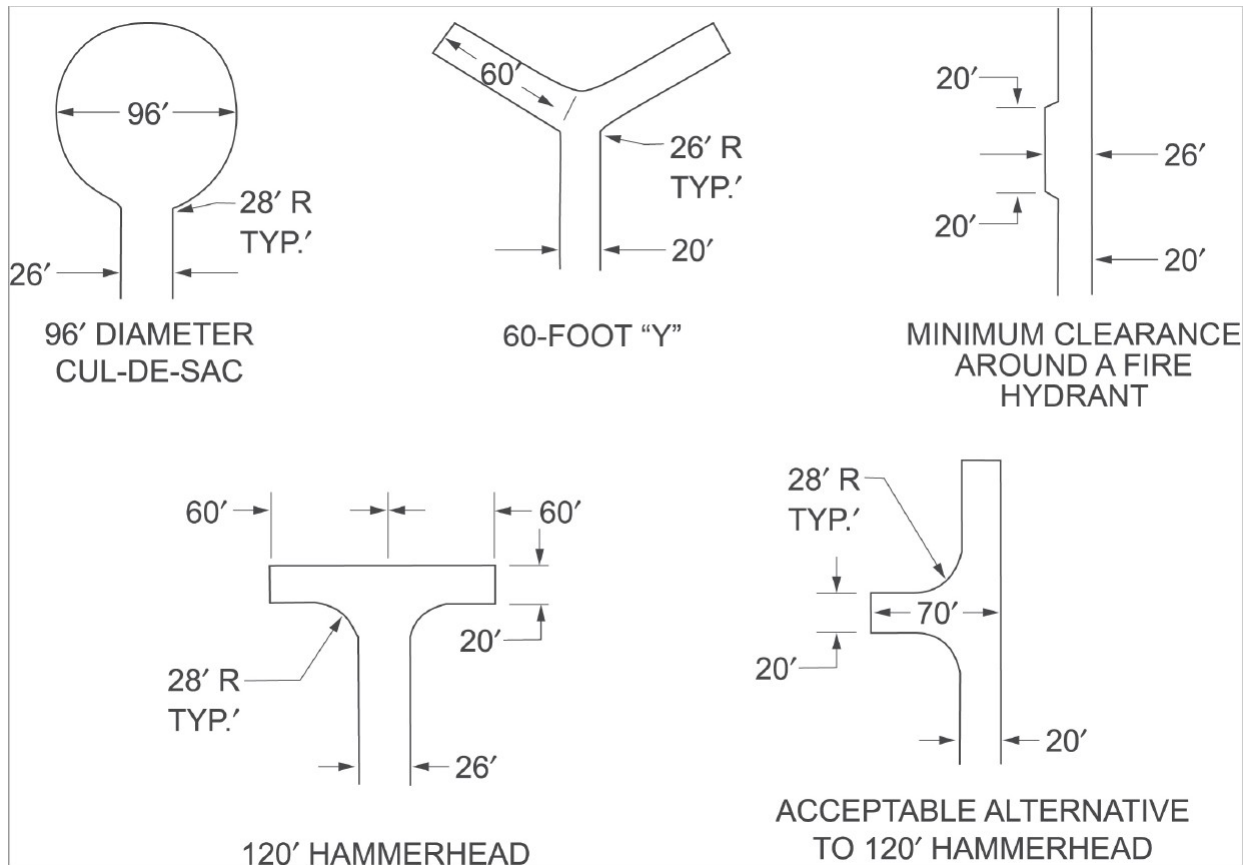

Figure D103.1, Dead-end Fire Apparatus Access Road Turnaround. Excepted from the 2021 International Fire Code. Copyright 2020. Washington, D.C.: International Code Council. Reproduced with permission. [www.iccsafe.org](http://www.iccsafe.org)

- (f) All private roads which serve more than one (1) single family or duplex residential lot shall be reviewed by the Planning Commission prior to the issuance of a building permit. The purpose of the review is to assure that the private road will comply with the requirements of this Ordinance and that the development of the private road will not impose or impact on the public interest. A person, firm, or corporation which desires to install a private road that serves more than one (1) single family or duplex residential lot shall apply to the Planning Commission for review of the proposed private road, and shall submit:

- (1) A site plan showing compliance with the provisions of this Section and the fee and escrow established for such review by the resolution of the Township Board, as adopted and established from time to time.
- (2) A permit for the access point of the private road issued by the Muskegon County Road Commission.
- (3) Written approval of the private road name by Muskegon County Dispatch
- (4) A copy of the private road maintenance agreement
  - (g) As part of its review, the Planning Commission shall consider the following matters, at a minimum:
    - (1) The number of single family or duplex residential lots served by the private road and how they are affected by the private road.
    - (2) The Township Fire Chief's review and whether emergency vehicles can safely access and exit all parcels served by the private road.
    - (3) Whether the private road meets the specifications of this Ordinance.
      - (4) The impact of the road on wetlands and/or dunes or other environmentally sensitive lands.
      - (5) When computing any required setbacks under the provisions of this Ordinance, setbacks shall be computed from the edge of the private road easement.
    - (h) Upon completion of the private road, and prior to final approval, the road shall be inspected and approved by the Township Engineer at the Applicant's expense. Once approved, the Zoning Administrator may issue building permits for the parcels serviced by the private road. (ord. 2023-01 adopt.12-29-2023)
    - (i) For any new parcel created on an existing, approved private road created prior to September 27, 2024, the private road must meet the current private road standards prior to a building permit being issued.

**110.320      Lot Splits**

Section 3.20. Whenever a lot of record within the Township is intended to be divided to create two or more lots, the owner or owner's agent shall provide to the Zoning Administrator an application for the lot split authorization and a drawing legal description of the existing lot and the proposed lots.

Each proposed lot or parcel resulting from the proposed lot split shall conform to all site development standards for the zoning district in which they are located.

The Zoning Administrator shall review the application and determine whether the resulting lots in the proposed lot split conform to the requirements of this Ordinance. If the Zoning Administrator determines the proposed lots do comply with the requirements of this Ordinance, the Administrator may issue approval for proceeding with the proposed lot split.

Whenever the Zoning Administrator shall determine the proposed lot split does not conform to the requirements of this Ordinance, the application for lot split shall be denied with the reasons for denial provided in writing to the applicant.

Any lot of record split into two or more lots after the effective date of this Ordinance which has not been approved under the terms of this Ordinance shall be deemed an illegal lot split and a nuisance per se.

#### **110.321 Signs and billboards.**

(a) Intent and Purpose: The intent of this section is to regulate the type, number, physical dimensions, and placement of signs in Casnovia Township. The purpose of these requirements is to:

- (1) Promote the public health, safety, and welfare of residents and visitors;
- (2) Reduce distractions to motorists and pedestrians that may be hazardous;
- (3) Protect commercial districts from visual clutter and chaos;
- (4) Protect property values; and
- (5) Protect the rural character and natural beauty of Casnovia Township.

(b) Definitions: As used in this ordinance the following terms and words are defined as follows:

- (1) Sign. Any display, figure, painting, drawing, placard, poster or other device visible from a public way that is designed, intended or used to convey a message, advertise, inform or direct attention to a person, institution, organization, activity, place, object or product. It may be a structure, or part thereof, painted oil or attached directly or indirectly to a structure.
- (2) Clear Vision Area. The area adjacent to the drive-way access to a property and public or private street. The clear vision area is that area that is within a triangle formed by connection Point "A" which is a point located along the street right of way that is thirty-five (35) feet from the intersection of the right of way line and the edge of the driveway access with Point 'B' which is a point located along the edge

of the driveway access that is thirty-five (35) feet from the intersection of the right of way line and the edge of the driveway access.

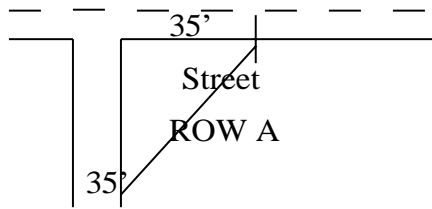

(3) Types of Signs defined:

- (i) Nameplate. A sign indicating the name, address or profession of the person occupying the lot or a part of a building.
- (ii) Bulletin board. An announcement sign that directs attention and is located on the lot of a public or semipublic institution.
- (iii) Identification sign. A sign indicating the name, owner or manager of an existing project or building.
- (iv) Real Estate sign. A sign advertising the sale, rental or lease of the premises or part of the premises on which the sign is displayed.
- (v) Project sign. A sign which directs attention to the promotion, development and construction of the property on which it is located and which identifies the architects, engineers, contractors and other individuals or firms involved with the construction.
- (vi) Business sign. A sign advertising the name of the business or establishment, the goods or commodities sold, or services rendered, on the property on which the sign is located.
- (vii) Directional sign. A sign indicating the direction to a specific business. The sign shall include no more than the name of the business in question and an arrow for the direction.
- (viii) Informational sign. A sign which is designed to give general information to the public concerning the location of places for lodging or eating, vehicle service, public offices or facilities, historic sites, or similar information.
- (ix) Political sign. A sign advocating action on a public issue or indicating a candidate for public office.
- (x) Temporary sign. A sign of any type that is on wheels or any other nonpermanent construction that is placed on property where the business is located to announce special events or sales, that is intended by the owner or lessee of the property to be used for thirty (30) days or less and is not of intended to be repeatedly used throughout the year.
- (xi) Seasonal agricultural sign. A sign that is placed within Casnovia Township to advertise or direct customers to seasonal farm markets or agricultural road side stands on farms within Casnovia Township that have a substantial or significant portion of its stock in trade consisting of produce or farm related products grown or produced within Casnovia Township.

- (xii) Lighted Sign. Any sign having a conspicuous, continuous or intermittent variation in the illumination of the physical position of any part of the sign. [Ord. # 2018-02, effective 07/09/2018]

(4) Structural Types of Signs defined:

- (i) Wall or Panel sign. A sign integral with the exterior face of a building or attached to the wall and projecting not more than twelve inches from the wall.
- (ii) Window sign. A sign painted, attached or affixed to the interior or exterior surface of windows or doors of a building.
- (iii) Projecting sign. A sign, other than a wall sign, erected on the outside wall of a building and which projects out at an angle perpendicular to the wall.
- (iv) Canopy sign. A sign attached to a canopy of a covered entrance or walkway or to a permanent awning or marquee
- (v) Ground sign. A freestanding sign which is supported by one or more poles, posts or braces in or upon the ground and which does not extend higher than fifteen (15) feet above the finished grade
- (vi) Pole sign. A sign which is supported wholly by a pole or poles in or upon the ground and which is extended above the finished grade so that the bottom of the sign is located a minimum of fifteen (15) feet above the finished grade and the top of the sign is located a maximum of one-hundred (100) feet above the finished grade.
- (vii) Billboard. A sign, also known as an "Outdoor Advertising sign" that is not located on the property for which the advertisement is intended. Seasonal Agricultural Signs shall not be considered Billboard.

(c) *Exempted Signs*: The following signs are exempt from the regulations of this section:

- (1) Garage or yard sale signs
- (2) Signs on private property indicated "No Hunting; No Trespassing."

(d) Application Requirements Pertaining to All Signs and Billboards:

- (1) No person shall erect or relocate or cause to be erected or relocated, any sign or billboard without first obtaining a sign permit except for those exceptions or exemptions expressly stated in this ordinance. [Ord. #01-2006 effective 10-27-2006]
- (2) No person shall repair or alter, or cause to be erected or altered, any sign or billboard if the repair costs exceed two-thirds of the value of the sign.

(e) Procedure for Obtaining a Sign Permit: Sign permit forms will be provided by the Zoning Administrator and shall contain at least the following:

1. Name, address, and telephone number of the applicant, and that of owner of the premises upon which the sign or billboard is to be erected.
2. A drawing, to scale, showing the location of the sign or billboard in relation to lot lines and existing structures.
3. Two (2) drawings of the plans and specifications with detail on the size of the sign, the method of construction, and method of attachment to a structure or ground.
4. The name of the person, firm, or corporation erecting the sign or billboard.
5. The written consent of the owner of the structure or the land upon which the sign or billboard is to be erected.
6. Each applicant, except seasonal agricultural sign applicants, shall pay a permit fee as may be established from time to time by the Township Board.
7. All billboards must obtain a building permit in addition to a zoning permit.

(f) Issuance of Sign Permit: The Zoning Administrator shall examine all data and proposed premises. If the proposed sign or billboard complies with the requirements of this Ordinance, the provision of all building codes and state law, the Zoning Administrator shall issue the sign permit. Such permit shall be void if all work authorized by such permit has not been completed within a six (6) month period, starting from the time of issuance of that permit.

(g) Billboards: Billboards as defined in this ordinance shall be prohibited except in Commercial and Industrial Districts that are located along state highways (M-37 and M-46). All Billboards must comply with this ordinance as well as the regulations of the State Highway Advertising Act (Act 106 of 1972) as amended.

(h) Signs Permitted In All Districts That Shall Not Require a Zoning Permit:

The following signs, defined in this ordinance, are permitted in all zoning districts and shall not require the issuance of a sign permit. However the signs listed in this section must be in conformance with the requirements of Section 3.21 (a) and all other applicable provisions of this Ordinance: [Ord. # 01-2006, effective 10/27/2006]

(1) Project Signs

- (2) Political Signs
- (3) Directional Signs
- (4) Informational Signs
- (5) Real Estate Signs
- (6) Name plates
- (7) Seasonal Agricultural Signs

(i) Regulations for Signs Permitted In All Districts: Regulations for the above listed signs that are allowed in all districts are:

- (1) One (1) construction sign for each street frontage at a construction project, not exceeding thirty (30) square feet in sign area. Such signs may be erected no more than thirty (30) days before commencement of construction and must be removed not later than thirty (30) days after completion of construction.
- (2) Seasonal Agricultural signs not to exceed two by three feet (2' x 3') or six (6) square feet in sign area. The number of signs permitted and the location of the signs must be approved by the Zoning Administrator. A refundable deposit of \$25.00 must be filed at time of approval to insure removal of the signs within six (6) months.
- (3) One nameplate sign per premises, provided such sign does not exceed four (4) square feet in sign area.
- (4) Directional signs may be placed outside of the right of way with permission of the property owner so long as such sign does not exceed two by three feet (2'x3') or six (6) square feet in sign area. The number of signs permitted and the location of the signs must be approved by the Zoning Administrator.
- (5) Political signs may be placed outside of the right of way with permission of the property owner so long as such sign is not posted more than thirty (30) days before the election to which the sign pertains and so long as the sign is removed within seven (7) days of the election to which the sign pertains

(j) Signs Permitted only in Agricultural and Residential Districts: All signs noted in this Section may only be placed on the same property as the business or use that the sign is meant to advertise.

- (1) One (1) non-illuminated ground sign per entrance road for use as a subdivision identification sign to identify permitted platted subdivisions or site condominium developments. Ground sign not to exceed thirty (30) square feet in sign area.

- (2) For permitted nonresidential uses, one (1) non-illuminated ground sign not to exceed sixteen (16) square feet in sign area and placed a minimum of twenty (20) feet from all lot lines.
  - (3) For nonresidential uses permitted with Special Use authorization signs shall be permitted as recommended by the Planning Commission and approved by Township Board following site plan review.
  - (4) In Agricultural Districts; one (1) non-illuminated sign advertising sale of agricultural related produce or products, not to exceed sixteen (16) square feet in sign area.
  - (5) Any illuminated sign should be a Special Land Use Permit with conditions. *[Ord. # 2018-02, effective 07/09/2018]*
- (k) Signs Permitted only in **Commercial and Industrial Districts**: All signs noted in this Section may only be placed on the same property as the business or use that the sign is meant to advertise.
- (1) One (1) ground sign or one (1) pole sign per premises not to exceed sixty-four (64) square feet in sign area. A ground sign may not exceed eight (8) feet in height. The maximum height of any pole sign shall be forty (40) feet.
  - (2) One (1) wall sign for each use located within a building. Total area of the wall sign not to exceed thirty percent (30%) of the building wall. The wall sign must be attached to the building and parallel to the building.
  - (3) Directional signs up to three (3) square feet in sign area.
  - (4) No sign other than pole signs shall project above a building roof line.
  - (5) All illuminated signs must be shielded from adjacent residential properties.
  - (6) Sign Illumination. There shall be no flashing, oscillating, or intermittent illumination of any sign. All illuminated signs shall be designed and located to prevent the light therefrom from being cast upon adjoining residences and shall be located at least one hundred (100) feet from any residential district. Illumination includes all types of artificial light. The illumination of any sign shall not be detrimental or annoying to surrounding property owners or occupants, nor constitute a safety hazard as determined by the Zoning Administrator. For purposes of this section, "flashing" means any change in sign face by electronic means for less than a continuous 30 second duration. *[Ord. # 2018-02, effective 07/09/2018]*

(l) *Prohibited Signs*: The Following Types of Signs are **Prohibited in All Zoning Districts**:

(1) Abandoned Signs

(2) Signs imitating or resembling official traffic or government signs or signals

(m) Sign Setbacks: All signs shall be set back beyond the road right of way and must be placed a minimum of ten (10) feet from side lot lines, except where otherwise required by this Ordinance. No sign shall be placed within the Clear Vision Area as defined by this ordinance.

(n) Temporary Signs: Temporary signs advertising a specific event are allowed following a site plan review and approval by the Zoning Administrator. As for temporary signs relating to specific events sponsored by non-profit organizations and public/municipal entities; including but not limited to: churches, governmental units, public charities and schools; a sign permit shall not be required. However, all such signs shall conform to all other requirements of this Ordinance. *[Ord. # 01-2006, effective 10/27/2006]*

(o) Maintenance of Signs and Billboards: The owner of any sign or billboard shall paint all parts of the sign at least once every two (2) years, unless it is galvanized or otherwise treated to prevent rust or deterioration. All signs shall be well maintained and kept in good repair. *[New section 3.21 Ord. # 032702, effective 5/9/2002]*

### Section 3.22.

### **KEEPING OF PETS, ANIMALS AND LIVESTOCK.**

The keeping of domesticated animals on lands in the A-1, A-2, R-1, R-2, and R-3 zoning districts shall be subject to the following provisions:

(a) Ordinary household pets such as dogs and cats and other animals customarily kept as pets shall be permitted in the A-1, R-1, R-2, R-3 and PURD zoning districts. Lands in the R-3 zoning district shall also be subject to requirements included in Section 7A.02(c).

(b) In the A-1 and R-2 zoning districts up to six (6) chickens, roosters, or other fowl shall be permitted for every half acre of land on parcels one (1) acre in area or larger. Excluding intensive farm operations, on parcels three (3) acres in area or larger, there shall be no limit, but the ratio of hens to roosters shall be no more than 1:1, favoring hens. No roosters shall be permitted in R-1. In the R-1 zoning district up to six (6) chickens or fowl other than roosters shall be permitted for every half acre of land on parcels one (1) acre in area or larger.

(c) Livestock such as, but not limited to, horses, cattle, llamas, goats, pigs, and sheep are permitted in the A-1 and R-2 zoning districts in accordance with the following:

- (1) On parcels of fifteen (15) acres or less the number of such livestock shall not exceed one (1) livestock for the first two (2) full acres of fenced in pastureland.
- (2) One (1) additional livestock for every additional one (1) full acre of fenced pasture shall be permitted.
- (d) Livestock such as, but not limited to horses, cattle, goats, pigs, and sheep are prohibited on any lands in the R-1 zoning district.
- (e) Any building or confined feeding area in which livestock are confined or fed (not including feeding by grazing) shall be located at least one hundred (100) feet away from any road right of way line and two hundred (200) feet from any adjacent lot line.
- (f) Livestock shall be fenced or penned with materials sufficient to contain animals within property lines. Any animals running at large shall be prima facie evidence that the enclosure was not sufficient.
- (g) The keeping of animals not generally considered to be domestic by the County Animal Control authorities and endangered species are prohibited unless property licensed. The keeping of said animals shall be in quantities no greater than those permitted for domestic animals and shall be permitted by Special Use permit only. The procedures and standards of Article 17 shall be followed.
- (h) Animal raising, animal husbandry, and the keeping of farm animals accessory to farms or dwellings shall be permitted in accordance with the Michigan Department of Agriculture and Rural Development's (MDARD) Generally Accepted Agricultural and Management Practices (GAAMPs).

Section 3.23.                    **OPEN SPACE PRESERVATION DEVELOPMENTS**

The following conditions shall apply to this section to be consistent with the requirements of Public Act 177 of 2001 mandating townships which meet certain qualifying conditions must provide for open space preservation development of land at the developers option.

- (i) *DEFINITIONS.* Words and phrases referred to in this section shall have the same meaning as defined in Public Act 177 of 2001.
- (j) *QUALIFYING CONDITIONS.* Land may be developed as an Public Act177 Open Space Preservation Development only if all of the following conditions are satisfied:
  - (1) The subject land is in the A-1, R-1 or R-2 zoning districts and subject to required density provisions.
 

The applicable zoning regulations permit development at a density equivalent to two (2) or fewer dwelling units per acre, if the land is not served by a public sewer system; or at a density equivalent to three (3) of fewer dwelling units per acre, if land is served by a public sewer system.
  - (1) The proposed development shall be under unified ownership or control, so that

one person or entity has proprietary responsibility for full completion of the project. The applicant shall provide sufficient documentation of ownership or control in the form of agreements, contracts covenants and/or deed restrictions indicating that the development will be completed in its entirety as proposed.

(2) The Public Act 177 of 2001 Open Space Preservation Development option provided for in the article shall not have previously been exercised with respect to the same land.

(b) *APPLICATION AND REVIEW PROCEDURE.* An Open Space Preservation project application shall be reviewed by the Planning Commission in accordance with the standards contained within these regulations and Article 17 **SPECIAL LAND USE PERMITS**, as well as Article 19 **SITE PLAN REVIEW STANDARDS**. The applicant shall submit twelve (12) sets of the Open Space Preservation Development plan.

(1) The site plan for an Act 177 Open Space Preservation Development shall include the following additional information:

(i) The portions of the land that are proposed to remain in a perpetually undeveloped state and portions of the land that will be used for development, including building lots street rights of way, drainage and other facilities needed for the development.

(1) The total number of acres proposed to remain in a perpetually undeveloped state, the number of acres proposed to be developed and the percentage of each, as compared to the total site acreage.

(2) The location of all proposed lots and proposed building envelopes and the lot area and width of each lot, and a demonstration that the minimum front, side and rear building setbacks of the district can be satisfied. The number of proposed lots on the site development shall not exceed the number of lots on the parallel plan.

(2) The application shall also include a parallel plan, which demonstrates the number of dwelling units that could be developed on the land under its existing zoning, without PUD approval or any variance approved by the Zoning Board of Appeals. The parallel plan shall include at least the following information:

(1) Date, north arrow and scale not more than 1" = 100'.

- (2) Locations and dimensions of streets and driveways, and computation of total area included in rights of way.
  - (3) Lot layout, dimensioned to show lot area and width.
  - (4) Location of all public or private utilities and improvements that would be necessary to serve a development and which would not be located within any public road right-of-way or private street easement, or on buildable lots. Such utilities include, but are not limited to, stormwater retention basins, community sewage treatment systems and community water supply facilities.
  - (5) If development under the parallel plan would require the use of septic tanks, drain fields and/or water wells, the location of all septic tanks and drain field areas along with written documentation from the Muskegon County Health Department that at least forty percent (40%) of the lots are suitable for on-site disposal systems. The Planning Commission may require a greater percentage to verify that the site can actually be developed as presented.
  - (6) The parallel plan shall illustrate all unbuildable land, with slopes of twenty percent (20%) or greater, regulated and unregulated wetlands, public utility easements, floodplains and other similar features which prevent construction of buildings and roads.
- (3) The applicant shall submit, before final approval of the project, a copy of the legal instrument that would run with the land and have the legal effect of reserving in perpetuity the required open space. Such legal instrument shall be subject to review and approval by the Township Attorney prior to recording with the County Register of Deeds. At a minimum, the legal instrument shall:
- (i) Indicate the proposed use of the undeveloped open space.
  - (ii) State the parties who have an ownership interest in the open space.
  - (iii) Require that the open space be maintained in perpetuity in an undeveloped condition, without buildings, structures or other improvements except such drainage improvements, utility lines, hiking trails, picnic areas, park or playground equipment or similar improvements that may be approved by the Planning Commission.
  - (iv) Require that the open space be maintained by parties who have an ownership interest in the open space.

- (v) Provide for scheduled maintenance of the open space by the owners. In the event that the dedicated open space is inadequately maintained or is determined to be a public nuisance, any maintenance costs incurred by the Township shall be assessed to the owners of the property within the Open Space Preservation project.
  
- (c) *MAXIMUM NUMBER OF LOTS.* The maximum number of lots in a Public Act 177 Open Space Preservation Development is the maximum number of complying, feasible lots which could be developed on the land in question if each lot met the minimum requirements of the zoning district in which it is located, as determined by the Township based on the parallel plan.
  
- (d) *OPEN SPACE REQUIREMENTS.* Not less than fifty percent (50%) or more than sixty percent (60%) of the land proposed for development under the provisions of this section shall remain in a perpetually undeveloped state by means of a conservation easement, plat dedication, restrictive covenant or other legal instrument that runs with the land, as approved by the Township Attorney. The following areas shall not constitute open space:
  - (1) The area within all public or private road rights-of-way.
  - (2) Any golf course
  - (3) The area within a platted lot, site condominium unit or metes and bounds parcel occupied or to be occupied by a building or structure not permitted to be located in open space.
  - (4) Detention or retention ponds created to serve the project.
  - (5) Any area devoted to public or common community sewage disposal systems or drain fields.
  - (6) Off street parking areas.
  - (7) 50% of the area of wetlands, creeks, streams, existing ponds or lakes or other bodies of water within the boundaries of the proposed project.
  
- (e) *STANDARDS FOR OPEN SPACE.* The following standards shall apply to the preserved open space required by this section:
  - (1) A portion of the open space shall be located along the public street frontage abutting the land. The depth of this area shall be at least fifty (50) feet, not including the public right-of-way, and this area shall be left in its natural condition or be landscaped to help to preserve or enhance the existing view.
  - (2) The open space may include a recreational trail, picnic area, children's play area

ball fields or other use which, as determined by the Planning Commission is substantially similar to these uses.

- (3) The open space shall be reasonably accessible and useable for all residents of the development, subject to reasonable rules and regulations.
- (4) If the land contains a lake, stream or other body of water, the Planning Commission may require that a portion of the open space abut the body of water.
- (5) No buildings or structures or improvements may be located in the open space, unless such structures and/or improvements directly promote the purposes of the open space.

(f) *DEVELOPMENT REQUIREMENTS.*

- (1) Open space preservation projects shall be served by either public or community water and sanitary sewer or by private wells and septic systems. The applicant shall submit proof that any proposed sanitary system(s) and well locations have been evaluated or approved by the Muskegon County Health Department.
- (2) In order to accommodate both the required open space and the number of lots permitted according to the parallel zoning plan the Planning Commission shall allow a reduction in the minimum lot size and building setback requirements of the zoning district in which the open space preservation project is located. For open space preservation projects the minimum lots sizes and lot width shall not be less than the following:

Zoning District	Minimum Lot Size	Minimum Lot Width
A-1 and R-2 Districts	20,000 square feet	110 feet
R-1 without both public or community sewer and water.	15,000 square feet	100 feet
R-1 with either public or community sewer or water.	10,000 square feet	85 feet

- (3) The development of lands under this section shall otherwise comply with all requirements of this Ordinance applicable to the zoning district in which the land is located except for lot size and width. Lots for dwellings in the clustered portion of the development shall be as uniform as is reasonably practicable.
- (4) Grading shall comply with the following requirements:
  - (i) To preserve the natural appearance of the land, grading shall be kept to minimum. Specific requirements may be placed on the area of land to be

graded.

- (ii) All areas indicated as open space on the approved development plan shall be undisturbed by grading, excavating, structures or otherwise unless approved by the Planning Commission based on the finding that the disturbance or structure enhances the open space.
  - (iii) Grading shall be planned and carried out to avoid erosion, pollution, flooding or other adverse effects upon the land.
- (5) Private roads which are part of an open space preservation project shall comply with the requirements for private roads as contained in section 3.19 of this Ordinance.
- (6) The development of an Act 177 Open Space Preservation Development is subject to all other applicable Township ordinances, county, state and federal statutes or regulations. The approval may be conditioned on the applicant receiving necessary permits before final site plan approval or occupancy permit is granted.
- (7) The Planning Commission may require reasonable performance guarantee in accordance with section 19.05 (f) Conditions and Plan Approval of this ordinance.
- (8) Areas of natural drainage such as swales, wetlands, ponds or swamps shall be protected and preserved insofar as practical in their natural state to provide areas for natural habitat, preserve drainage patterns and maintain the natural characteristics of the land. [New section 3.23 Ord. # 03-2008, effective 12/26/2008]

**Section 3.24. PUBLIC UTILITY FACILITIES AND WIND ENERGY CONVERSION SYSTEMS (WECS)**

*(a) Intent and Purpose*

- (1) Purpose. The most common and prevalent land use in Casnovia Township is agricultural, and its preservation has been an ongoing goal within the community for many years. This Ordinance is intended to protect the health, safety and welfare of the residents of the Township and to encourage the safe, effective, efficient and orderly development and operation of wind energy resources in the Township while preserving and protecting the character and the stability of residential, agricultural, recreational, commercial and other areas within the Township.
- (2) With advances in technology of “wind energy development” in general, specific locations within the Township may support the implementation of Utility Grid Wind Energy Systems. To prepare for potential “wind development projects” within the Township, this Ordinance will require such developments to obtain a Special Land Use Permit to ensure wind development sites are appropriately located so as to protect the character and stability of the Township’s residential,

agricultural, recreational, commercial and/or industrial areas and character while simultaneously preserving and protecting the Township's important and sensitive environmental and ecological assets and areas, open space, view scapes and aesthetics, wetlands, and other ecological and environmentally sensitive areas. Accordingly, regulations are necessary to further the above goals and, equally important, to minimize the potential adverse effects of this emerging land use on adjacent properties.

(b) Findings

- (1) This Ordinance has been developed with the intention of obtaining an appropriate balance between the desire for renewable energy resources and the need to protect the public health, safety, and welfare of the community and the character and stability of the Township's residential, agricultural, recreational, commercial and/or industrial areas and preserving and protecting the Township's important and sensitive environmental and ecological assets and areas, open space, viewsapes and aesthetics, wetlands, and other ecological and environmentally sensitive areas.
- (2) Based on evidence presented in this State and others concerning the adverse secondary effects of wind energy systems on communities, including, but not limited to, findings from the Wind Turbine Health Impact Study: Report of Independent Expert Panel, prepared for the Massachusetts Department of Environmental Protection (2012); Strategic Health Impact Assessment on Wind Energy Development in Oregon, prepared for the State of Oregon (2012); Potential impact on the Public's Health from Sound Associated with Wind Turbine Facilities, prepared for the State of Vermont's Department of Health (2010); Analysis of the Research on the Health Effects from Wind Turbines, Including Effects From Noise, prepared for the Maine Department of Health and Human Services (2012); Jeffrey et al, "Adverse Health Effects of Industrial Wind Turbines," 59 Can Fam Physician 473-475 (2013); Salt, A., and Kaltenbach, J, Infrasound From Wind Turbines Could Affect Humans, 31(4) Bulletin Science, Technology and Society, 296-302 (2011), the following are among the potential harmful secondary effects of wind energy systems:
  - (i) Falling ice or "ice throws" is physically harmful and measures should be taken to protect the public from the risk of "ice throws."
  - (ii) Nighttime wind turbine noise can cause sleep disturbance. Generally, sleep disturbance can adversely affect mood, cognitive functioning and one's overall sense of health and well-being. Chronic stress and sleep disturbance could increase the risk for cardiovascular disease, decreased immune function, endocrine disorders, and mental illness. In addition, possible health effects include increased heart rate, insomnia, fatigue, accidents, reduction in performance and depression.
  - (iii) Sound from wind energy facilities could potentially impact people's health and well-being if it increases background sound levels by more than 10 dB(A) or results in long term outdoor community sound levels above 35-40 dB(A).

- (iv) There is evidence that wind turbine sound is more noticeable, annoying and disturbing than other community industrial sounds at the same level of loudness.
- (v) People who live near wind turbines are more likely to be impacted by wind turbines than would those far away.
- (vi) Alternating changes in light intensity caused by the moving blades of wind turbines on the ground and stationary objects, also known as shadow flicker, can cause health issues.
- (vii) The Township desires to protect ecological and environmentally sensitive areas in the Township, including, but not limited to, habitats for endangered species or heavily used migration routes for species of waterfowl and other migratory birds (some of which are protected species). Thus, the Township has determined that wind development sites can adversely impact wildlife and their habitats and makes evaluation of proposed wind development sites essential. The Township finds that any wind development sites should have the lowest potential for negative impacts on wildlife resources and avoid locations with higher concentrations of migratory birds. Further, any wind development sites that would fragment sensitive habitat areas, like rivers, streams, and wetlands, should be avoided.
- (viii) The general welfare, health, and safety of the citizens of the Township will be promoted by the enactment of this ordinance.

(c) Definitions

- (1) Participating Landowner: A landowner who has leased land to the WECS Applicant, received financial remuneration from the WECS Applicant, recorded with the Muskegon County Register of Deeds said agreement, and has a contract with the WECS Applicant. A Participating Landowner may also be called a WECS contract leaseholder. A Participating Landowner may or may not have turbines or infrastructure located on their property.
- (2) Non-Participating Landowner: A landowner who has not signed a contract or any legal document with the WECS Applicant and has not given up rights to their owned land to the WECS Applicant.
- (3) SCADA (supervisory control and data acquisition): A computer system that monitors and controls WECS units.
- (4) dBA: The A-weighted sound level.
- (5) dBC: The C-weighted sound level.
- (6) Pasquill Stability Class: Reference, wikipedia.org "Outline of air pollution dispersion".
- (7) Adverse Sound Character: Sound that causes building rattle, is impulsive, tonal, or has low-frequency bass rumble.
- (8) ANSI: the American National Standards Institute.
- (9) Audible: The varying degrees of sound perception as reported by affidavit, including, but not limited to, just perceptible, audible, clearly audible, and objectionable.
- (10) Decibel (dB): The practical unit of measurement for sound pressure level; the

number of decibels of a measured sound is equal to 20 times the logarithm to the base 10 of the ratio of the sound pressure of the measured sound to the sound pressure of a standard sound (20 microPascals); abbreviated "dB."

- (11) Emergency work: Any work or action necessary to deliver essential services in an emergency situation, including, but not limited to, repairing water, gas, electricity, telephone and sewer facilities and public transportation, removing fallen trees on public rights-of-way, and abating life-threatening conditions.
- (12) Equivalent Sound Level (or Leq): The sound level measured in decibels with an integrating sound level meter and averaged on an energy basis over a specific duration.
- (13) Excessive noise: Sound that is determined by ordinance to be too loud or unnecessary or creates a noise disturbance.
- (14) Ambient: Ambient is defined as the sound pressure level exceeded 90% of the time over a 96-hour measurement period with daytime/nighttime division.
- (15) Noise: A sound, especially one that is loud or unpleasant or that causes disturbance. Any airborne sounds of such level and duration as to be or tend to be injurious to human health or welfare (well-being) or that would unreasonably interfere with activities or the enjoyment of life or property.
- (16) Quiet Rural or Residential property: Any property where there is an inherent expectation of quiet, including, but not limited to, all residential, business, or agricultural-zoned properties, single family homes, and retirement homes.
- (17) Sound level meter: An instrument for the measurement of sound levels that meets the ANSI requirements of S1.4-1983 (or later revision) for Type 1 or 2 instruments. For frequency analysis, octave and 1/3 octave filters shall conform to ANSI S1.11-1986 (or later revision).
- (18) GIS: Geographic Information System and is comparable to GPS (global positioning system) coordinates.
- (19) Survival Wind Speed: The maximum wind speed, as designated by the WECS manufacturer, at which a WECS in unattended operation (not necessarily producing power) is designed to survive without damage to any structural equipment or loss of the ability to function normally.
- (20) Tip Height: The height of the turbine with a blade at the highest vertical point.
- (21) Wind Energy Conversion System (WECS): Any combination of the following:
  - (i) A mill or machine operated by wind acting on oblique vanes or sails that radiate from a horizontal shaft;
  - (ii) A surface area such as a blade, rotor, or similar device, either variable or fixed, for utilizing the wind for electrical or mechanical power;
  - (iii) A shaft, gearing, belt, or coupling utilized to convert the rotation of the surface area into a form suitable for driving a generator, alternator, or other electricity-producing device;
  - (iv) The generator, alternator, or another device to convert the mechanical energy of the surface area into electrical energy;
  - (v) The tower, pylon, or other structure upon which any, all, or some combination of the above are mounted.
  - (vi) Any other components not listed above but associated with the normal

construction, operation, and maintenance of a wind energy conversion system.

- (22) WECS Applicant: The person, firm, corporation, company, limited liability corporation or other entity, as well as the Applicant's successors, assigns and/or transferees, which applies for Township approval (permit) to construct a WECS and WECS Testing Facility. An Applicant must have the legal authority to represent and bind the Participating Landowner, or lessee, who will construct, own, and operate the WECS or Testing Facility. The duties and obligations regarding a zoning approval for any approved WECS or Testing Facility shall be with the WECS or Testing Facility owner, and jointly and severally with the owner, operator, and lessee of the WECS or Testing Facility if different than the WECS owner.
- (23) Wind Energy Conversion System (WECS) Testing Facility: A structure and equipment such as a meteorological tower for the collection of wind data and other meteorological data and transmission to a collection source, shall not be deemed to be a communication tower.
- (24) L10: Is the noise level exceeded for 10% of the time of the measurement duration. This is often used to give an indication of the upper limit of fluctuating noise, such as that from road traffic.
- (25) L90: Is the noise level exceeded for 90% of the time of the measurement duration and is commonly used to determine ambient or background noise level.

(d) Public Utilities. Transmission lines, sewer lines, water mains, pumping stations, substations, poles, and related equipment owned or provided by public utility companies or by the Township shall be permitted in all zoning districts. Any equipment enclosures, substations, equipment storage buildings or similar structures shall be subject to the site plan review requirements of Article 19. Any office, manufacturing, or sales buildings must be located in the Commercial or Industrial zoning district. All communication towers or commercial wind energy conversion systems operated by public utility companies shall be subject to the requirements of section "Commercial Wind Energy Conversion Systems (WECS)". Unless specifically noted, all WECS permit information and supporting documentation shall be allocated reasonable Township review time based on complexity and outside expertise review. Requirements shall be presented in written form and allow minimum thirty (30) days before Township discussion. Township may at its discretion review provided documents sooner than thirty (30) days. Providing documents without time for Planning Commission to review shall result in permit denial and require WECS applicant to reapply. Each ordinance section requires approval by the Planning Commission unless otherwise noted. Township shall review all documentation to assure that residents' health, welfare, and safety are not negatively impinged.

(e) Exempt Towers and Wind Energy Conversion Systems (WECS). Communication towers, antennas, wind energy conversion systems (windmills, turbines) and related facilities located on the premises of a farm, home, or business and which do not

primarily involve the sale of electricity or communication services off the premises shall be exempt from the requirements of section "Commercial Wind Energy Conversion Systems (WECS)". However, exempt towers and WECS are subject to the following noise regulations of the Casnovia Township Zoning Ordinance: Article 2, Section 2.42 and Article 3, Section 3.12. Such units shall be allowed as a permitted accessory use in all zoning districts, providing the electricity or communication services are primarily used on site for a farm, home or business. In the case of a WECS, the total height with the blade fully extended (Tip Height) shall not exceed one hundred thirty (130) feet, and the minimum clearance from ground level to the blade at its lowest point shall be twenty (20) feet. The minimum set-back from property lines and road right of way lines shall be equal to 3 times the Tip Height of the unit (WECS blade at its highest point).

- (f) Commercial Wind Energy Conversion Systems (WECS). Wind energy conversion systems and WECS testing facilities, other than those exempted under section (e) "Exempt Towers and Wind Energy Conversion Systems (WECS)", shall only be allowed as special land uses in the A-1 Exclusive Agricultural Zoning District. An application for a special land use permit shall be filed with the Township pursuant to Article 17 as to Special Land Use approvals. Supporting data and documentation must be submitted in their entirety at time of application. Applicant shall provide to the Township updated documents throughout the lifespan of the WECS upon request by the Township Board or Planning Commission. Applicant shall also include the following:

- (1) **Permitting Costs:** An escrow account shall be set up when the Applicant applies for a Special Use Permit for a WECS and WECS Testing Facilities. The monetary amount filed by the Applicant with the Township shall be in an amount in accordance with the Township Escrow Policy to cover all reasonable costs and expenses associated with the special use zoning review and approval process, which costs can include, but are not limited to, fees of the Township Attorney, Township Planner, and Township Engineer, as well as any reports or studies which the Township anticipates it may have done related to the zoning review process for the particular application. Such escrow amount shall include regularly established fees. At any point during the zoning review process, the Township may require that the Applicant place additional monies into the Township escrow should the existing escrow amount filed by the Applicant prove insufficient. If the escrow account needs replenishing and the Applicant refuses to do so within fourteen (14) days after receiving notice, the zoning review and approval process shall cease until and unless the Applicant makes the required escrow deposit. Any escrow amounts which are in excess of actual costs shall be returned to the Applicant within ninety (90) days of permitting process completion. An itemized billing of all expenses shall be provided to the Applicant. The Township shall hire qualified professionals for each and any of the technical fields associated with the Special Use Permit, such as, but not limited to, electrical, acoustics, environment, economics, wildlife, health, and land-use.

- (2) Environmental Assessment: The Applicant shall fund an environmental assessment or impact study and other relevant report(s) or studies (including, but not limited to, assessing the potential impact on endangered species, eagles, birds, and/or other wildlife) as required by the Township for review. Studies shall be limited to the area within three (3) miles outside of the Township boundaries.
- (1) The Applicant shall perform pre-construction ground water testing on all wells located within the required setback distance of a proposed turbine location. The operation of the WECS shall not negatively impact any groundwater well or groundwater source in the vicinity of the WECS. Complaints regarding impact of the WECS on groundwater sources shall be promptly forwarded to the Township Board as part of the complaint resolution process. The Township Board will consider proof of a negative impact arising from the installation and/or operation of the WECS on a groundwater well or source in the vicinity of the WECS as a violation of the conditions of the special use approval.
- (2) A background (ambient) sound study shall be performed and a report provided which indicates Leq 1 second, L10, and L90 sound levels using A-weighting and C-weighting. Data shall be collected at midpoints along property lines of adjoining Non-Participating and Landowners Participating. Measurement procedures are to follow the most recent versions of ANSI S12.18 and ANSI S12.9, Part 3 guideline (with an observer present). Measurements shall be taken using an ANSI or IEC Type 1 Precision Integrating Sound Level Meter. The study must include a minimum of a four-day (96 hour) testing period, include one Sunday, and divide data by daytime and nighttime. The sound background study shall report for the period of the monitoring topography, temperature, weather patterns, sources of ambient sound, and prevailing wind direction.
- (3) Economic Impact: The Applicant shall fund and provide an economic impact study for the area affected by the WECS project. Such a study shall include probable financial impact regarding jobs, tax revenue, lease payments and property values at a minimum and average set-backs distances. Business and residential growth potential shall be considered.
- (4) Site Plan: The Applicant shall submit a site plan in full compliance with Article 19 of this Ordinance. The Applicant shall also submit a written explanation of the design characteristics and the ability of the structure(s) and attendant facilities to withstand winds, ice and other naturally occurring hazards, as well as information regarding health, welfare and safety in areas including, but not limited to, noise, vibration, shadow flicker, and blade ice deposits. This information shall also address the potential for the WECS to structurally fail or collapse, and what results should be expected in such an event. Additional requirements for a WECS site plan are as follows:

- (1) Building Siting: GIS locations and height of all proposed buildings, structures, electrical lines, towers, guy wires, guy wire anchors, security fencing, and other above-ground structures associated with the WECS.
- (2) Nearby Building Siting: GIS locations and height of all adjacent buildings, structures, and above ground utilities located within three (3) times minimum set-back distance for Non-Participating Landowners where the proposed WECS and WECS Testing Facility will be located. The location of all existing and proposed overhead and underground electrical transmission or distribution lines shall be shown, whether to be utilized or not with the WECS or Testing Facility, located on the lot or parcel involved.
- (3) Access Driveways: GIS location of WECS and Testing Facility access driveways together with details regarding dimensions, composition, and maintenance of the proposed driveways. The site plan shall include traffic routes, time of the year use, staging areas, and any other physical sites related to WECS. Construction of the Access Driveway that serves a WECS or Testing Facility is required to protect the public health, safety, and welfare by offering an adequate means by which governmental agencies may readily access the site in the event of an emergency. All such roads shall be constructed to allow access at all times by any emergency service vehicles, such as fire, police, and repair. Access driveways shall be no closer than 300' to adjacent property unless Applicant provides documentation in the form of a signed approval by affected Participating and Non-Participating Landowners. Such approval shall be recorded with Muskegon County Register of Deeds using only the WECS Waiver Form Revision 1 or later.
- (4) Facility Security: Security measures shall be sufficient to prevent unauthorized trespass and to protect health, welfare, and safety.
- (5) Maintenance Program and Resolution Program: The Applicant shall provide to the Township a written description of the problem and failure program to be used to resolve the any WECS and WECS Testing Facility issues, including procedures and schedules for removal when determined to be obsolete or abandoned.
- (6) Site Lighting: A lighting plan for each WECS and Testing Facility. Such plan must describe all lighting that will be utilized and documentation that FAA requirements are met. RADAR activated lighting shall be utilized if allowed by FAA. Such a plan shall include but is not limited to, the planned number and location of lights, light color, activation methods, effect on Township residents and whether any lights blink. Due to complexity in describing lighting effects for health, welfare, and safety, Applicant shall, if available, provide example locations with product descriptions, where similar, or proposed, lighting solutions are currently deployed. Lighting shall be fully shielded from ground, be FAA compliant, and be of most current design, to minimize lighting blinking and brightness nuisance.
- (7) Proof of any applicable documents recorded at the Muskegon Country Register of Deeds utilizing Article 1522 WECS Waiver Form Revision 1 (or

- later).
- (8) If there are any changes to any site plan for a WECS or Testing Facility, including any changes in road locations, road access, the location of accessory structure, and/or the location of any turbine, a revised site plan shall be submitted and approved prior to construction. Any revised site plan must provide revised calculations to address all of the items required under the original plan submission (i.e. setbacks, shadow flicker, noise, etc.).
  - (9) Supplemental: Additional detail(s) and information as requested by the Planning Commission.
- (5) Site Insurance: The Applicant shall provide proof of insurance for each WECS at all times for at least \$10,000,000 for liability, property damage, livestock damage, and future earnings loss. Applicant shall provide yearly proof of insurance to Township that confirms active coverage for the Applicant, Township, Participating Landowners, and Non-Participating Landowners. Aggregate policies are allowed if minimum coverage per WECS is satisfied and coverage is provided for every site where Applicant's equipment is located.
- (6) Removal Insurance (decommissioning): To ensure proper removal of each WECS structure when it is abandoned or non-operational, application shall include a proof of the financial security in effect before permit is approved. The security shall be licensed in the State of Michigan and be in the form of 1) cash deposit or 2) performance (surety) bond selected by the Planning Commission and bonded by a top institution from the Department of the Treasury's Listing of Approved Sureties -Department Circular 570, T-list. The duration of the security shall be termed to the removal of each WECS as stated in this Ordinance. Additionally, security is based on each WECS and is to be backed by owner assets, operator assets, parent company assets, and leaseholder assets approved by the Planning Commission.
- (1) The amount of each WECS security guarantee (surety) shall be the average of at least two independent (of Applicant) demolition (removal) quotes, obtained by the Planning Commission and approved by the Board, plus 10%. If the quantity of quotes obtained is two, the formula shall be  $(\text{quote1} + \text{quote2})/2 * 1.10$ . The security guarantee shall be no less than \$800,000 per WECS. Quotes shall be based on individual WECS removal and shall not group multiple WECS simultaneous removals together. Quotes shall be ordered and obtained by the Township from established demolition companies. The demolition method shall be approved by the Township Board. Quotes shall not include salvage values. Security guarantee shall be updated every five (5) years at the rate of 1.5 times CPI (consumer price index) for each year.
  - (2) Such financial guarantee shall be deposited or filed with the Township Clerk after a special use has been approved but before construction operations

begin on the WECS project. Failure to keep such financial security in full force and effect at all times while the structure exists shall constitute a material and significant violation of a special use approval and this ordinance and shall subject the Applicant to all available remedies to the

**Township, including enforcement action, fines, revocation of the special use approval and WECS removal.**

- (3) The Applicant shall be responsible for the payment of all attorney fees and other costs incurred by the Township in the event that the structure is not voluntarily removed and the Township has to enforce removal.
- (4) In the event the WECS owner, operator, parent company, performance bond defaults on any or all of the previously outlined decommissioning requirements, the Participating Landowner upon which each WECS is located shall be responsible and liable for the removal of each WECS. Failure of the Participating Landowner to comply with the removal and decommissioning guidelines shall result in the Township having the WECS removed at the expense of the Participating Landowner. If funding is not available to cover the costs of removal by the Participating Landowner, legal action to pursue the seizure of Participating Landowner property(ies) will take place to cover such costs.
- (7) Safety Manual: The Applicant shall provide an unredacted copy of the manufacturer's safety manual for each model of turbine without distribution restraints to be kept at the Township Hall and other locations deemed necessary by Planning Commission or local first responders. The Manual should include standard details for an industrial site such as materials, chemicals, fire, access, safe distances during WECS failure, processes in emergencies, etc.
- (8) Repair Policy Documentation: Applicant shall provide a detailed policy and process book for the repair, replacement, and removal of malfunctioning, defective, worn, or non-compliant WECS. Sections of the process book should consider any ordinance requirement or WECS performance deficiency.
- (9) Noise: Applicant shall provide an initial sound modeling report and a 6-month post-construction report for the project with a schedule and documentation which adhere to the following:
  - (1) Chart outlining ordinance requirements and a description of compliance or non-compliance.
  - (2) Declaration whether submitted data is modeled or measured.
  - (3) Declaration of values, test methods, data sources, and similar for all modeled or measured data.
  - (4) Estimated timeline for project including ordinance requirements completed, construction, post construction, and validation testing.
  - (5) Applicant measured data shall be accompanied by SCADA data confirming full power during testing. Unless otherwise requested, minimum SCADA

data format shall be grouped in 24hr periods and 1 second intervals including wind vector, wind speed, temperature, humidity, time-of-day, WECS power output, WECS amps, WECS volts, WECS nacelle vector, WECS blade RPM, WECS blade pitch.

- (6) Permitting data may be submitted based on WECS manufacturer data. However, measured data from active and similar WECS facilities shall be simultaneously submitted.
- (7) It is acknowledged that WECS units sustain wear over time. Applicant is to submit data from existing and similar WECS installations showing aged sound measurements (to demonstrate compliance potential over the life of WECS) in accordance with this ordinance for 5, 10, and 15-year-old units.
- (8) Modeling factors shall be set for the worst-case environment, such as high humidity, frozen ground (non-porous), atmospheric variances (atmospheric profile Pasquill Stability Class E or F preferred), elevated noise source and no ground cover. Use of modeling methods (standards) shall have deficiencies (limitations) fully disclosed and shall include known error margins. Non-disclosure of modeling method deficiencies shall require resubmission of SLUP in its entirety with complete modeling deficiencies disclosed.

(g) Commercial Wind Energy Conversion Systems (WECS) – Standards and Requirements.  
The WECS project shall meet the following standards and requirements:

- (1) Set-Back: The minimum set-back from any property line of a Non-Participating Landowner or any road right-of-way shall be no less than four (4) times Tip Height of WECS or WECS Testing Facility unless Applicant provides documentation in the form of a signed approval by affected Participating and Non-Participating Landowners waiving these requirements. Documents in full shall be recorded using only the WECS Waiver Form Revision 1 or later, with the Muskegon County Register of Deeds. For WECS, use turbine pole centerline as WECS measuring point.
- (2) Ground Clearance: The minimum clearance from ground level to the blade at its lowest point shall be one hundred (100) feet.
- (3) Applicant Compliance: The WECS and related equipment shall comply with any and all State, Federal, County and Township requirements.
- (4) Blade Clearance: Blade arcs created by a WECS shall have a minimum of one hundred (100') feet of clearance over and from any structure.
- (5) Braking: Each WECS shall be equipped with a braking, or equivalent device, capable of stopping the WECS operation in high winds with or without SCADA control. Braking system shall be effective during complete GRID power failure where WECS are unable to communicate with SCADA control or receive power.
- (6) Signage: Each WECS and Testing Facility shall have one sign per turbine, or tower, located at the roadside and one sign attached to base of each WECS,

easily visible throughout four seasons. Signs shall be at least two square feet in area. Signs shall be the same and shall uniquely identify each WECS. Signage shall comply with Article 3 Section 3.21 Signs and Billboards. Additional signage on and around the tower is recommended. The sign shall contain at least the following:

- (i) Warning high voltage.
  - (ii) Participating land owner's name, WECS owner's name, and operator's name.
  - (iii) Emergency telephone numbers and web address. (list more than one number).
  - (iv) If WECS uses fencing, place signs on the perimeter fence at fence entrance door.
  - (v) Unique identification such as address of WECS. If more than one WECS on access drive, units shall have further identification such that first responders can positively identify. An identification example is "321 Ruger Rd, Caro, MI Unit A"
- (7) Communication Interference: Each WECS and Testing Facilities shall be designed, constructed and operated so as not to cause radio and television or other communication interference. In the event that verified interference is experienced and confirmed by a licensed engineer, the Applicant must produce confirmation that said interference had been resolved to residents' satisfaction within ninety (90) days of receipt of the complaint. Any such complaints shall follow the process stated in Complaint Resolution section (g)(25).
- (8) Infrastructure Wiring: All electrical connection systems and lines from the WECS to the electrical grid connection shall be located and maintained underground. Burial depth shall be at a depth that causes no known environmental, land use, or safety issues. Depth shall be a minimum of 6ft below grade, be deeper than drain tile and be in compliance with NEC 2014 or newer Code standards. All utility lines shall be staked in the field, so as to provide notice to property owners as to the location of utilities, including installing a marker at 4-feet below-grade to identify the utility line location.

The Planning Commission may waive the burial requirement and allow above-ground structures in limited circumstances, such as geography precludes, or a demonstrated benefit to the township. The waiver shall not be granted solely on cost savings to Applicant. Request for variation shall consider aesthetics, future use of land, and effect on nearby landowners.

- (9) Road Damage: The Applicant shall post a financial security in the form of a surety bond from a surety company that is listed as an acceptable surety on Federal Surety Bonds in circular 570 of the U.S. Department of Treasury, or letter of credit from, or an escrow account established in, a financial institution licensed in the State of Michigan for the cost of repairs of Muskegon County roads within the Township, in an amount of \$1,250,000. The amount and standards for road repair work shall be determined by a third party road inspector appointed by mutual agreement of the Township, Applicant and Muskegon County Road Commission. The bond shall only be released (in whole or in part) when the Township Board, in consultation with the Muskegon County Road Commission and said third party inspector, determines that all required road work has been completed and approved by the road inspector in consultation with the Muskegon County Road Commission and/or MDOT. The Township may consult with the third party road inspector to verify the proposed bond amount of \$1,250,000. If the third party inspector determines that the amount needed for road repairs and upgrades is higher, the Applicant will post a financial security in the amount determined by the third party inspector. All road repairs must be complete within ninety (90) days of project completion, or maintenance completion, but shall not exceed 365 days from project commencement or maintenance completion.
- (10) Road Use Agreement: The Applicant shall provide and execute a Road Use Agreement with the Township and shall file a copy of such Agreement with the Township Clerk before construction of any accessory road and/or road improvements. The Road Use Agreement is subject to review and approval of the Township attorney. The Applicant shall provide a written status report annually to the Township Board as to the ongoing scope of road work and shall also provide written notice to the Township Board when all required road work has been completed. The Township may require the renewal of the bond for road work to cover costs of road work to be completed in the future.
- (11) Liability Insurance: The current WECS owner and operator shall insure for liability for the WECS without interruption until removed and comply with section "Site Insurance" to protect the current WECS owner and operator, Township and property owner.
- (12) Coating and Color: A WECS shall be painted a non-obtrusive (light environmental color such as beige, gray or off-white) color that is non-reflective. The wind turbine base and blades shall be of a color consistent with all other turbines in the area. No striping of color or advertisement shall be visible on the blades or tower.
- (13) Strobe Effect: Under no circumstances, shall a WECS or Testing Facility produce shadow flicker, or strobe-effect, on properties without a signed release from affected Participating and Non-Participating Landowners. Documents in full shall be recorded using only the WECS Waiver Form Revision 1 or later, with the

Muskegon County Register of Deeds. Each wind turbine shall also use a shadow flicker mitigation system, including but not limited to the Vestas Shadow Detection System, or other similar system.

- (14) Ice Detection: The Applicant shall install an ice detection system on each turbine, including but not limited to the system developed by Vestas, or other similar system, to monitor ice formation on each wind turbine (WECS) and to facilitate immediate shutdown of any wind turbine if ice is detected on the turbine.
- (15) Fire Suppression: The Applicant shall provide and install on an WECS a fire suppression system, including but not limited to Fire Trace or other similar system, and insure that such system is operable at all times.
- (16) Voltage: The Applicant shall demonstrate WECS prohibits stray voltage, surge voltage, and power from entering ground, and shall correct any voltage issued that is caused by the WECS.
- (17) Protection of Adjoining Property: In addition to the other requirements and standards contained in this section, the Planning Commission shall not approve any WECS or Testing Facility unless it finds that the WECS or Testing Facility will not pose a safety hazard or unreasonable risk of harm to the occupants of any adjoining properties or area wildlife.
- (18) Removal and Site Renovation: A condition of every approval shall be adequate provision for the removal of the structure in its entirety whenever it ceases to actively produce power for one hundred eighty (180) days or more. The Planning Commission can grant an extension of an additional one hundred eighty (180) days upon the WECS owner demonstrating that the structure will be put back into use. Removal shall include the proper receipt of a demolition permit from the Building Official and proper restoration of the site to original condition. Removal of the structure, wiring, and its accessory use facilities shall include removing the caisson and all other components in their entirety. Restoration must be completed within 365 days of non-operation. The Planning Commission can grant an extension of one hundred eighty (180) days upon the WECS owner demonstrating that an extension is necessary.
  - (i) Participating Landowners may waive complete underground wiring removal if they can demonstrate that any and all remaining underground wiring will not negatively affect environment, such as, but not limited to, water quality, natural water flow, or area wildlife. Participating Landowner shall execute a waiver and record same in full with Muskegon County Register of Deeds waiving these requirements.

- (19) WECS Height: The maximum Tip Height of any WECS or WECS Testing Facility shall not exceed 500 ft.
- (20) Avian Protection: Each wind turbine shall have a bird/bat sensor installed and utilized upon it.
- (21) Post-Construction Studies: The applicant shall prepare a post-construction avian and wildlife study 1-year post-construction, as well as 5-years post-construction of the completion of a WECS, which shall comply with the requirements of the U.S. Fish and Wildlife Service and the Michigan Department of Natural Resources. A copy of the study shall be provided to the Township Board.
- (22) Post-Construction Documents: The Applicant shall provide a complete set of as built drawings for electrical structures, collection lines and surface markings to the Township Clerk within 6 months of completing work on the WECS.
- (23) Operations Training: The Applicant shall provide training for the Casnovia Township Fire Department and all fire departments that provide mutual aid to Casnovia Township before beginning operations of the Utility Grid Wind Energy System and shall likewise provide regular training at least annually thereafter. The Applicant shall report annually to the Township Board as to the status of the training of the Township Fire Department, in addition to reporting annually to the Township Board of any incidents that required response by the Fire Department (or any Fire Departments responding via mutual aid) to the WECS.
- (24) Operational, Maintenance, and Issue Resolution: Each WECS and Testing Facility must be kept and maintained in good repair and condition at all times. If a WECS is not maintained in operational and reasonable condition or poses a potential safety hazard, the Applicant shall take expeditious action to correct the situation, including WECS removal. The Applicant shall keep a maintenance log on each WECS and must provide complete log to the Township within thirty (30) days of request.
- (25) Complaint Resolution: A complaint resolution process shall be established by the township. The form shall be, but not limited to:
  - (i) Receiving and Forwarding of Complaints: A third party answering switchboard, website or equivalent, paid for by the Applicant or WECS or Testing Facility owner. The cost to maintain and support shall be funded in the amount of \$10,000.00 and be replenished at least every five (5) years by the Applicant or WECS owner. The Planning Commission shall select a complaint resolution process that is independent of the facility operator or owner and that reports to the Township first and operator second. Upon

receiving a complaint, the Township shall forward said complaint to the WECS owner.

- (ii) Investigation of Complaints: Township shall initiate an investigation into a complaint within sixty (60) days utilizing escrow funds to hire the appropriate expert(s).
  - (iii) Hearing of Complaints: Township Board shall set a public hearing date within sixty (60) days of completion of Investigation of Complaints where experts, residents and/or Applicant may present information before the Township Board. Notice of hearing shall be via certified mail.
  - (iv) Decision of Complaints: Township Board shall issue a decision and corrective actions within forty-five (45) days from Hearing of Complaints.
- (26) Applicant shall be required as a condition of approval to fund an escrow account for investigation of complaints for, but not limited to, shadow flicker, stray voltage, noise, and signal interference to the amount of \$15,000.00 to be used at the discretion of the Casnovia Township Board. When escrow account balance is below \$5,000.00, Township shall notify Applicant and Applicant shall replenish account in the amount of \$15,000.00 within 45 days.
- (27) Regulation of WECS Commercial and Industrial Noise: To preserve quality of life, peace, and tranquility, and protect the natural quiet of the environment. This ordinance establishes the acoustic baseline, background sound levels for project design purposes, and limits the maximum noise level emissions for commercial and industrial developments. Residents shall be protected from exposure to noise emitted from commercial and industrial development by regulating said noise.
- (28) The Township Board reserves the right to require WECS Applicant to shut down any WECS unit that does not meet ordinance requirements until such WECS unit meets ordinance requirements or is removed.
- (29) Complaints: If the Township Board confirms and issues a corrective action, SCADA data from WECS within 2 miles of issue shall be required and delivered to Township within twenty (20) days of notification. SCADA data format shall be determined by Township, Township licensed engineers, or Township professional acousticians. Unless otherwise requested, minimum SCADA data format shall be grouped in 24hr periods and 1 second intervals including wind vector, wind speed, temperature, humidity, time-of-day, WECS power output, WECS amps, WECS volts, WECS nacelle vector, WECS blade RPM, WECS blade pitch. Fees for providing SCADA data are not to exceed \$100/request. Residents shall have the right to also request SCADA data in at least the minimum format at the cost of

\$200/WECS per time period requested. Common SCADA formats shall include meteorological and performance data such as, but not limited to, temperature, humidity, power output, RPM, wind velocity, wind direction, and nacelle vector. Data format shall be determined by Township, such as “csv” or “xlsx”.

(30) Noise:

- (i) No WECS shall generate or permit to be generated audible noise from commercial or industrial permitted facilities that exceeds 39 dBA or 49 dBC (dBC to dBA ratio of 10 dB per ANSI standard S12.9 Part 4 Annex D) during the night 9 pm to 8 am for any duration, at a property line or any point within a Non-Participating property, unless Applicant provides documentation in the form of a signed agreement by the Participating and Non-Participating Landowner waiving these requirements. Said documents in full shall be recorded with the Muskegon County Register of Deeds waiving these requirements. Documents in full shall be recorded using only the WECS Waiver Form Revision 1, or later, with the Muskegon County Register of Deeds.
- (ii) No WECS shall generate or permit to be generated plainly audible noise from commercial or industrial permitted facilities that exceeds 45 dBA or 55 dBC during the day 8 am to 9 pm for any duration, at a property line or at any point within a Non- Participating property, unless Applicant provides documentation in the form of a signed agreement by the Participating and Non-Participating Landowner waiving these requirements. Said documents in full shall be recorded with the Muskegon County Register of Deeds waiving these requirements. Documents in full shall be recorded using only the WECS Waiver Form Revision 1, or later, with the Muskegon County Register of Deeds.
- (iii) No WECS shall generate or permit to be generated from commercial or industrial permitted facilities any acoustic, vibratory, or barometric oscillations in the frequency range of 0.1 to 1 Hz that is detectable at any time and for any duration by confirmed human sensation or exceeds a sound pressure level from 0.1 to 20 Hz of 50 dB(unweighted) re 20uPA or exceeds an RMS acceleration level of 50 dB(unweighted) re 1 micro-g by instrumentation at a Non-Participating Landowner’s property line or at any point within a Non-Participating Landowner’s property.
- (iv) No WECS shall generate or permit to be generated from commercial or industrial permitted facilities any vibration in the low-frequency range of 0.1 to 20 Hz, including the 1, 2, 4, 8, and 16 Hertz octave bands that is perceivable by human sensation or exceeds an rms acceleration level of 50 dB(unweighted) re 1 micro-g at any time and for any duration either due to

impulsive or periodic excitation of structure or any other mechanism at a Non-Participating Landowner's property line or at any point within a Non-Participating Landowner's property.

- (v) A tonal noise condition generated from commercial or industrial permitted facilities shall be assessed an upward noise penalty of 5 dBA (example 42 increased to 47 dBA) for assessment to the nighttime and daytime noise limits.
  - (vi) A noise level measurement made in accordance with methods in section "NOISE MEASUREMENT AND COMPLIANCE" that is higher than 39 dBA or 49 dBC during the nighttime hours or 45 dBA or 55 dBC during the daytime hours, adjusted for the penalty assessed for a tonal noise condition, shall constitute prima facie evidence of a nuisance.
  - (vii) An acoustic, vibratory or barometric measurement documenting oscillations associated to commercial or industrial permitted facilities with levels exceeding the limits in 23 shall constitute prima facie evidence of a nuisance.
  - (viii) All commercial and industrial activity shall comply with limits and restrictions anywhere at any time on another property unless Applicant provides documentation in the form of a signed approval by affected Participating and Non-Participating Landowners. Documents in full shall be recorded with the Muskegon County Register of Deeds waiving these requirements. Documents in full shall be recorded using only the WECS Waiver Form Revision 1 or later, with the Muskegon County Register of Deeds.
  - (ix) Leq 1-sec shall be used for all measurements and modeling.
- (31) Casnovia Township and its representatives shall have the authority to inspect the WECS (any of the wind turbines, the roads and/or accessory structures) upon reasonable notice of at least 24 hours to the Applicant. The Applicant may require that a representative of the Applicant accompany the Township and/or its representatives on any inspection.
- (32) The Applicant shall enter a Host Agreement with Casnovia Township regarding taxation.
- (h) Noise Measurement and Compliance*
- (1) Post construction validation and compliance testing shall include a variety of ground and hub height wind speeds, at low (between 6-9mph) medium (between

9-22mph) and high (greater than 22mph). SCADA data shall be provided in the format determined by Township, Township licensed engineers, or Township professional acousticians. Compliance noise measurements are the financial responsibility of the WECS owner of the facility and shall be independently performed by a qualified professional acoustician approved by the Planning Commission when directed by the Casnovia Charter Township Board or their designated agent. Compliance noise measurements shall not exceed the stipulated noise limits and shall assess for and apply tonal noise penalties when warranted.

- (2) Quality: Measurements shall be attended. All noise measurements shall (must) exclude contributions from wind on microphone, tree/leaf rustle, flowing water, and natural sounds such as tree frogs and insects. The latter two can be excluded by calculating the dBA noise level by excluding octave band measurements above the 1000 Hz band as in ANSI S12.100 3.11. The ANS-weighted sound level is obtained by eliminating values for octave bands above 1000 Hz, or one-third octave bands above 1250 Hz, and A-weighting and summing the remaining lower frequency bands. The wind velocity at the sound measurement microphone shall not exceed 3 m/s (7 mph, maximum) during measurements. A 7-inch or larger diameter windscreen shall be used. Instrumentation shall have an overall internal noise floor that is at least 5 dB lower than what is being measured. During testing of elevated sources including, but not limited to, wind turbines, the atmospheric profile shall be Pasquill Stability Class E or F preferred, Class D as alternate.
- (3) Noise Level: Noise measurements shall be conducted consistent with ANSI S12.18 Procedures for Outdoor Measurement of Sound Pressure Level and ANSI S12.9 Part3 (Quantities and Procedures for Description and Measurement of Environmental Sound – Part 3: Short-term Measurements with an Observer Present), using Type 1 meter, A-weighting, Fast Response.
- (4) Tonal Noise: Tonal noise shall be assessed using unweighted (linear) 1/3 octave band noise measurements with time-series, level-versus-time data acquisition. A measurement shall constitute prima facie evidence of a tonal noise condition if at any time (single sample or time interval) the noise spectrum of the noise source under investigation shows a 1/3 octave band exceeding the average of the two adjacent bands for by 15 dB in low one-third octave bands (10–125 Hz), 8 dB in middle-frequency bands (160–400 Hz), or 5 dB in high- frequency bands (500–10,000 Hz).
- (5) Sample Metric and Rate: Noise level measurements for essentially continuous non-time- varying noise sources shall be acquired using the Leq(Fast) metric at a sample rate of 1-per- second. For fluctuating or modulating noise sources including, but not limited to, wind turbines, a 10-per-second sample rate or faster

shall be used. These sample rates shall apply to dBA, dBC and unweighted 1/3 octave band measurements.

- (6) Reporting: Measurements of time-varying dBA and dBC noise levels and 1/3 octave band levels shall be reported with time-series level-versus-time graphs and tables. Graphs shall show the sound levels graphed as level-vs-time over a period of time sufficient to characterize the noise signature of the noise source being measured. For 1-per-second sampling, a 5-minute-or-longer graph shall be produced. For 10-per-second sampling, a 30-second-or-longer graph shall be produced. Reporting shall identify, and graphs shall be clearly notated, identifying what was heard and when the noise source is dominating the measurement. Reporting shall furnish all noise data and information on weather conditions and, Pasquill Class occurring during testing.

*(i) Compliance*

- (1) All applicable requirements of the Zoning Ordinance must be met in their entirety as well as all other applicable laws, ordinances, and rules of the federal, state, county, and township governments. Any subsequent development or change on the property shall comply with all requirements of the Township Zoning Ordinance or other ordinances and regulations in effect at that time. Non-compliance with ordinance requirements during SLUP process shall result in denial or revocation of the permit.
- (2) Non-compliance with post-construction ordinance requirements shall result in fines (minimum \$250/day), permit denial, and WECS decommissioning.
- (3) Nuisance compliance complaints shall be resolved after section "Complaint Resolution" is completed. Applicant shall provide resolution plan within 30 days and resolve complaint within 90 days. WECS may be shut down during resolution time to extend resolution time to 180 days.
- (4) For non-nuisance compliance, and upon formal notice from Township or Resident to WECS permit holder, WECS permit holder shall respond within thirty (30) days with resolution plan, and up to one hundred eight (180) days to resolve compliance breach. Failure to resolve any compliance breach shall result in permit loss. Unless otherwise stated, Applicant shall provide in advance and comply with ordinance requirements prior to Township granting the permit. Conditional permits shall not be allowed.
- (5) In addition to any other remedies or complaint resolution procedures set forth in this Article, violations of this Article shall also constitute a municipal civil infraction in accordance with Ordinance Number 2012-02. Each day on which any violation of this Article continues shall constitute a separate offense. The

Township may bring an action for an injunction to restrain, prevent or abate any violation of this Article.

- (6) Upon change of ownership, operator or parent company, the Township shall receive from the new owner, operator or parent company notification and updated documents within 30 days including, but not limited to, legal proof of change, corporate legal contact, security bond updates, emergency contact, and local contact. [Revised section 3.24 Ord. # 2019-04, effective 10/24/2019]

### Section 3.25                    **JUNK VEHICLES.**

The purpose of this Ordinance is to discourage visual blights, to protect the health, safety and welfare of the persons within the township and to regulate the parking or storage of junk vehicles.

- (a) No person shall park, store, leave, or permit the parking, storing, or leaving, of any junk vehicles, whether attended or not, upon any private property within the township.
- (b) No person shall park, store, leave, or permit the parking, storing, or leaving, of any junk vehicle, whether attended or not, upon any public property within the township. The presence of a junk vehicle, or parts thereof, on public property, or on private property in violation of this Ordinance, is hereby declared a public nuisance, and is subject to being removed by the township to abate said nuisance
- (c) No owner of private property where a junk vehicle is parked or stored shall allow it to be used for habitation by any person or animal, wild or domestic. Nor shall any junk vehicle be permitted to be used as a receptacle for trash, junk or other debris.
- (d) The use of an ORV sticker shall not exempt stored vehicles from the provisions of this Ordinance except when the sole use of the vehicle is for recreational purposes when transported by trailer to off-premises locations. Vehicles with an ORV sticker must still meet the other provisions of this Ordinance and be either stored out of sight of adjoining premises or be located and covered with a tarp in the owner's side or rear yard.
- (e) Whenever a junk vehicle is located on private property within the township, a written violation notice shall be served by the township by posting said notice to the dwelling at which the vehicle is located, by first-class mail to the owner and the occupant of the subject property, and by first-class mail to the vehicle owner(s), if known.
- (f) Within ten (10) days after service of the violation notice, the owner of the subject property and/or the owner(s) of the junk vehicles shall be responsible for the removal of the vehicle(s) to bring the subject property in compliance with this Ordinance. If

the vehicle(s) is not removed peaceably within ten (10) days after service of the violation notice, the township, its agents and employees may enter upon the subject property and may remove the nuisance vehicle(s). Any expenses incurred by the township shall be paid by the vehicle owner and by the owner and occupant of the subject property, jointly and severally. If the expenses remain unpaid for 10 days after an invoice is mailed, the township shall have a lien against the subject property in the amount of the expenses incurred. The lien shall be enforced in the same manner as a tax upon real property and collected as provided by law. [New section 3.25 Ord. # 2014-02, effective 10/24/2014]

**Section 3.26 SWIMMING POOL.**

Pools used for swimming or bathing shall be in conformity

with the following provisions: [Revised section 3.26 Ord. #2017-04, effective 1/20/2017]

- (a) Zoning Compliance Permit and a building permit shall be obtained from the Township Zoning Administrator before the installation of a year-round above ground or in ground swimming pool. Seasonal swimming pools are required to obtain a Zoning Compliance Permit only. For purposes of the ordinance, a seasonal swimming pool is an on ground swimming pool capable of holding more than twenty-four (24) inches of water, and erected for a maximum of five (5) months during a twelve (12) month calendar year.
- (b) All swimming pools to be constructed shall be enclosed by a fence which shall be at least four (4) feet in height and which shall be of a type not readily climbed by children. The gates shall be self-closing and latching type with the latch on the inside of the gate, not readily available for children to open. Provided, however, that if the entire premises of the residence is enclosed, then this provision may be waived by the Building Inspector upon inspection and approval of the residence enclosure.
- (c) All swimming pools shall comply with the Michigan Building Code.
- (d) All year-round in-ground or on-ground swimming pools shall comply with the setback requirements for accessory buildings for the zoning district in which the swimming pool is located. Seasonal swimming pools shall be located not closer than ten (10) feet to any side or rear property line. Front yard setbacks shall be equal to the front yard setback for the zone district in which the pool is located, but at no time closer than twenty-five (25) feet to any road right of way. The pool shall be at least fifteen (15) feet from center of powerline right of way.
- (e) Swimming pools shall be properly maintained at all times and shall not become a safety or health hazard.

- (f) Spray ponds maintained by farms for agricultural purposes shall not be required to comply with the terms of this Ordinance, except for fencing as may be required by the Township Building Code.
- (g) Any person who shall violate any provisions of the Ordinance shall be subject to a civil infraction.

**Section 3.27            FENCES.**

In all residential and agricultural zoning districts, front and front side yard fences shall be no higher than 3 feet and no more than 50% solid. Fences within the side and rear yard may be as high as 6 feet and may be of solid material. Fencing may be placed on the lot line, observing clear corners per Section 3.16. All fencing in the Agricultural District utilized for the keeping of livestock or protection of crops is exempt from this section. In the case of waterfront lots, fences shall be no closer than 20 feet to the ordinary high-water mark. [amended 12/29/2023 Ord. 2023-2, eff 12/29/2023].

**SECTION 3.28            LARGE SOLAR ENERGY SYSTEMS**

- (a) *INTENT AND PURPOSE:* The most common and prevalent land use in Casnovia Township is agricultural and its preservation has been an ongoing goal within the community for many years. This Ordinance is intended to protect the health, safety, and welfare of the residents of the Township and to encourage the safe effective, efficient, and orderly development and operation of Large Solar Energy Systems in the Township while preserving and protecting the character and stability of residential, agricultural, recreational, commercial, and other areas within the Township.
  - (1) With advances in technology of solar energy development in general, specific locations within the Township may support the implementation of Large Solar Energy Systems. To support renewable energy/potential solar energy projects within the Township, this Ordinance will require such developments to obtain a Special Land Use Permit to ensure solar development sites are appropriately located so as to protect the character and stability of the Township’s residential areas , agricultural economy and soil health while simultaneously preserving and protecting the Township’s important and sensitive environmental and ecological assets and areas, open space, viewscapes, and aesthetics, wetlands, and other ecological and environmentally-sensitive areas. Accordingly, regulations are necessary to further the above goals and, equally important, to minimize the potential adverse effects of this emerging land use on adjacent properties.
- (b) *APPLICABILITY:* This chapter applies to utility-scale solar energy collector systems and does not apply to small-scale solar energy collector systems primarily for on-site usage.

- (1) Definition Large Principle Use Solar Energy System: Solar photovoltaic systems of energy or solar-thermal systems, which provide energy for off-site consumption, over 150 KW. On-site consumption is permitted as a secondary use.
  - (2) Definition Small Accessory Use Solar Energy System: Ground-mounted or roof mounted solar energy system for the purpose of generating electricity for principle use on site.
- (c) *SITE PLAN DRAWING AND SUPPORTING MATERIALS*: All applications for a Large Solar Energy Systems use must be accompanied by detailed site plans, drawn to scale and dimensioned and certified by a registered engineer licensed in the State of Michigan, displaying the following information:
- (1) All requirements for a site plan contained in Article 19 of the Casnovia Township Zoning Ordinance.
  - (2) All lot lines and dimensions, including a legal description of each lot or parcel comprising the Large Solar Energy System.
  - (3) Names of owners of each lot or parcel within Casnovia Township that is proposed to be within the Large Solar Energy System.
  - (4) Vicinity map showing the location of all surrounding land uses.
  - (5) Map showing adjoining land uses within 300 feet of the proposed Large Solar Energy System
  - (6) Location and height of all proposed Solar Array(s), buildings, structures, electrical tie lines and transmission lines, security fencing, and all aboveground structures and utilities associated with a Large Solar Energy System.
  - (7) Horizontal and vertical (elevation) to scale drawings with dimensions that show the location of the proposed Solar Array(s), buildings, structures, electrical tie lines and transmission lines, security fencing and all above ground structures and utilities on the property.
  - (8) Location of all existing and proposed overhead and underground electrical transmission or distribution lines within the Large Solar Energy System and within one hundred (100) feet of all exterior property lines of the Large Solar Energy System.
  - (9) Land elevations for the Solar Array(s) location and land elevations of all existing and proposed structures within the Large Solar Energy System at a minimum of five (5) foot contours.
  - (10) Access driveways within and to the Large Solar Energy System, together with a detailed narrative regarding dimensions, composition, and maintenance of each proposed driveway. All access drives shall be subject to Muskegon County Road Commission approval and shall be planned so as to minimize disruption to the farm operation or other existing land use.

- (11) Planned security measures to prevent unauthorized trespass and access during the construction, operation, removal, maintenance or repair of the Large Solar Energy System.
  - (12) A written description of the maintenance program, including schedules and types of maintenance to be performed, to be used for the Solar Array and other components of the Large Solar Energy System.
  - (13) Planned lightening protection measures.
  - (14) Additional detail(s) and information as required by the Special Land Use requirements of the Casnovia Township Zoning Ordinance, or as required by the Planning Commission.
  - (15) A written description of the decommissioning and removal plan including procedures and schedules if the Large Solar Energy System is decommissioned.
- (d) *APPLICATION ESCROW ACCOUNT*: An escrow account shall be deposited with the Township by the Applicant when the Applicant applies for a Special Land Use for a Large Solar Energy System.

The monetary amount deposited by the Applicant in escrow with the Township, as determined by the Township Board, shall cover all reasonable costs and expenses associated with the Special Land Use review and approval process, which costs shall include, but are not limited to, reasonable fees of the Township Attorney, Township Planner, and Township Engineer, as well as costs for any reports or studies that are reasonably related to the zoning review process for the application. Such escrow amount shall be in addition to any filing or application fees established by resolution. At any point during the Special Land Use review process, the Township may require that the Applicant place additional funds into escrow with the Township if the existing escrow amount deposited by the Applicant is deemed insufficient by the Township. If the escrow account needs replenishing and the Applicant refuses to do so within thirty (30) days, the Special Land Use process shall cease unless and until the Applicant makes the required additional escrow deposit. Any applicable zoning escrow Resolutions or other Ordinances adopted by the Township must also be complied with by the Applicant. The Township shall provide a summary of all account activity to the Applicant within a timely manner upon request. Any funds remaining within the escrow after approval of the Special Land Use shall be returned in a timely manner to the Applicant.

- (e) *CERTIFIED SOLAR ARRAY COMPONENTS*: Components of a Solar Array shall be approved by the Institute of Electrical and Electronics Engineers (“IEEE”), Solar Rating and Certification Corporation (“SRCC”), Electronic Testing Laboratories (“EIL”), or other similar certification organization if the similar certification organization is approved by the Township, which approval shall not be unreasonably withheld.

- (f) *LOCATION*: Solar energy equipment shall only be located in an area determined to be “not prime farmland” by the U.S. Department of Agriculture (USDA), per the USDA’s Farmland Classification Map as of the Date of Special Use Application for a Utility -Scale Solar Energy Collector System.
- (g) *GLARE AND REFLECTION*: The exterior surfaces of solar energy collectors shall be generally neutral in color and substantially non-reflective of light. A unit may not be installed or located so that sunlight or glare is reflected into dwellings on other lots or onto streets or private roads.
- (h) *ENERGY STORAGE SYSTEM*: When no longer in use, batteries must be properly disposed of in accordance with applicable laws and regulations. The energy storage system shall prevent leaking into groundwater and shall be designed to present no unacceptable risk to human health or the natural environment.
- (i) *HEIGHT*: Maximum height of a Solar Array, other collection device, components or buildings of the Large Solar Energy System, excluding substation and electrical transmission equipment, shall not exceed twenty (20) feet (as measured from the natural grade at the base of improvements to the highest point at full tilt) at any time or location on the property.

The Planning Commission may consider greater heights if a secondary property use, such as animal grazing, is suggested. **DUAL USES**: Dual land uses such as agriculture, pollinator habitat, grazing, or other conservation ground cover are encouraged.

- (j) *LOT SIZE, LOT COVERAGE, AND SETBACKS*:
  - (1) Lot Size: A Large Solar Energy System shall be located on one or more parcels with an aggregate area of ten (10) acres or greater.
  - (2) Setbacks: A minimum setback distance of fifty (50) feet from all exterior property lines of the Large Solar Energy System and existing public roads and railroad rights-of-way shall be required for all buildings and Solar Arrays, provided that a setback of seventy-five (75) feet shall be required adjacent to any residential structure (fences excluded). If two adjoining properties participate in the same project, the common lot line is not included in setback requirements.
  - (3) Lot coverage: A Large Solar Energy System is exempt from maximum lot coverage limitations if the area under the panels is pervious surface.
  - (4) Interior access drives shall be limited to the extent practical to minimize soil compaction.
- (k) *SECURITY*: A Large Solar Energy System shall be completely enclosed by perimeter security fencing to restrict unauthorized access. Such fencing shall be at least six (6) feet in height with a one (1) foot extension arm consisting of a minimum of three strands of barbed-wire placed above the fencing and slanting outward as measured

from the natural grade of the fencing perimeter, seven (7) feet in height without barbed wire, or eight (8) foot deer fence. Electric fencing is not permitted. The Planning Commission may consider other types of fencing if the Applicant can prove it will meet NEC and NESC requirements while retaining rural aesthetics. The security gate must be approved by the Casnovia Fire Department for emergency access.

- (l) *GROUND COVER*: A native, perennial ground cover shall be provided to stabilize soil and prevent sedimentation runoff to neighboring properties. The Planning Commission may consider exceptions for sites such as brownfield, agrivoltaic, etc.
  
- (m) *SCREENING AND BUFFERING*: The perimeter of Large Solar Energy Systems shall also be screened and buffered by installed evergreen or native vegetative plantings whenever existing natural vegetation does not otherwise reasonably obscure the Large Solar Energy System from adjacent property residential structures, subject to the following requirements:
  - (1) The buffer shall be composed of deciduous or evergreen trees that at planting shall be a minimum of four (4) feet in height and shrubs two (2) feet in height. The evergreen trees shall be spaced no more than fifteen (15) feet apart on center (from the central trunk of one plant to the central trunk of the next plant), deciduous trees shall be placed no more than thirty (30) feet apart on center and shrubs shall be spaced no more than seven (7) feet apart on center. All unhealthy (sixty (60) percent dead or greater) and dead material shall be replaced by the Applicant within one (1) year, or the next appropriate planting period, whichever occurs first.
  - (2) All plant materials shall be installed between March 15 and November 15. If the Applicant requests a Final Certificate of Occupancy from the Township and the Applicant is unable to plant during the installation period, the Applicant will provide the Township with a letter of credit, surety or corporate guarantee for an amount equal to one and one-half (1.5) times the cost of any planting deficiencies that the Township shall hold until the next planting season. After all plantings have occurred, the Township shall return the financial guarantee.
  - (3) Failure to install or continuously maintain the required vegetative buffer shall constitute a violation of this Ordinance and any Special Land Use may be subject to revocation.
  
- (n) *SIGNAGE*: One six square foot sign is permitted at the entrance gate area. Any other signs containing points of contact or any and all other information that may be required by authorities having jurisdiction for electrical operations and the safety and welfare of the public will also be permitted no larger than six square feet.

- (o) *NOISE*: No component of any Large Solar Energy System shall emit noise exceeding forty-five (45) dBA (Leq [1hour]) at the property line of an adjoining non-participating lot as measured at the exterior property boundary. The site plan shall include modeled sound isolines extending from the sound source to the property lines to demonstrate compliance with the standard.
- (p) *LIGHTING*: All lighting for parking lots, driveways, external illumination of buildings, or the illumination of signs shall be directed away from and be shielded from adjacent properties and shall be so arranged as to not adversely affect driver visibility on adjacent public roads. Shall also be dark sky compliant.
- (q) *DISTRIBUTION, TRANSMISSION, AND INTERCONNECTION*: All collection lines and interconnections from the Solar Array(s) to any electrical substations shall be located and maintained underground inside the Large Solar Energy System, except in areas where technical or physical constraints make it preferable to install equipment above ground. This requirement excludes transmission equipment meant to connect the project substation to the local transmission system.
- (r) *ABANDONMENT AND DECOMMISSIONING*: Following the operational life of the project, the Applicant shall perform decommissioning and removal of the Large Solar Energy System and all its components. The Applicant shall prepare a decommissioning Plan and submit it to the Planning Commission for review and approval prior to issuance of the Special Land Use. Under this plan, all structures, concrete, piping, facilities, and other project related materials above and below grade shall be removed offsite for disposal.

Any Solar Array or combination of Photovoltaic Devices that is not operated for a continuous period of twelve (12) months shall be considered abandoned and shall be removed under the Decommissioning Plan. The ground must be restored to its original topography within three hundred sixty-five (365) days of abandonment or decommissioning. Restoration shall also include bringing soil to agricultural-grade composition, as determined by Muskegon County Soil and Water Conservation, to ensure agricultural use upon restoration. Soil tests shall be required as a part of the Decommissioning Plan both before development and prior to decommissioning.

- (1) The applicant will obtain a surety bond for reclamation in an amount to be determined by Township Engineer as a condition of site plan approval.
- (2) The Engineer will be able to review the size of the farm and the number of solar panels that will be installed. The amount of the surety bond would fluctuate depending on the size of the farm. Once the Engineer sets the surety bond amount, be sure to confirm that the applicant obtains it. This shall be a condition

of site plan approval. The value of the bond shall be reviewed every five years and updated accordingly.

- (3) The surety bond is to remain in place for the length of the leases/contracts.
- (s) *GENERAL STANDARDS*: The Planning Commission shall not approve any Large Solar Energy System Special Land Use unless it finds that all of the general standards for Special Land Uses contained in Section 17.06 of this Ordinance are met.
- (t) *APPROVAL TIME LIMIT AND EXTENSION*: Special Land Use and Site Plan approvals, under this Section, shall be valid for one (1) year beginning on the date of Township Board approval. Once commenced, should construction cease for period of twelve (12) consecutive months, the Special Land Use and Site Plan approvals shall be considered null and void. If construction begun prior to the expiration date established by Township Board approval, the Special Land Use and Site Plan approvals shall remain in force as long as construction continues toward a reasonable date of completion. However, if requested by the Applicant prior to the expiration date established by Township Board approval, the Township Board may consider an additional one-year period upon showing of good cause for the extension.
- (u) *CONDITIONS AND MODIFICATIONS*: Any conditions and modifications approved by the Planning Commission shall be recorded in the Planning Commission's Casnovia Township meeting minutes. The Planning Commission may, in addition to other reasonable conditions, require landscaping, walls, fences and other improvements that are reasonable in relation to and consistent with the nature of the applicable or adjacent zoning districts. After approval, at least two (2) copies of the final approved Site Plan shall be signed and dated by the Chairperson of the Planning Commission and authorized representative of the Applicant. One copy shall be kept on file by the Township Clerk, and one copy shall be returned to the Applicant's authorized representative.
- (v) *INSPECTION*: The Township shall have the right at any reasonable time, to provide a twenty-four (24) hour notice prior to the desired inspection to the Applicant to inspect the premises on which any Large Solar Energy System is located. The Township may hire one or more consultants, with approval from the Applicant (which shall not be unreasonably withheld), to assist with inspections at the Applicant's or project owner's expense. Inspections must be coordinated with, and escorted by, the Applicant's operations staff at the Large Solar Energy Facility to ensure compliance with the Occupational Safety and Health Administration (OSHA), NESC and all other applicable safety guidelines.

- (w) **MAINTENANCE AND REPAIR:** Each Large Solar Energy System must be kept and maintained in good repair and condition at all times. If the Township Zoning Administrator determines that a Large Solar Energy System fails to meet the requirements of this Ordinance and the Special Land Use, or that it poses a safety hazard, the Zoning Administrator, or his or her designee, shall provide notice to the Applicant of the safety hazard. If, after a reasonable cure period (not to exceed 7 days), the safety hazards are not corrected, the Applicant is entitled to a hearing before the Township Board. If the Township Board determines that the safety hazard requires that the Large Solar Energy System must be shut down, Applicant shall immediately shut down the Large Solar Energy System and not operate, start or restart the Large Solar Energy System until the issues have been resolved. Applicant shall keep all sites within the Large Solar Energy System neat, clean and free of refuse, waste or unsightly, hazardous or unsanitary conditions.
- (x) **TRANSFER OF OWNERSHIP:** Prior to a change in the ownership or operation of a solar energy collector system, including but not limited to the sale or lease of that system or the underlying property, the current owner or operator shall provide written notice to the Township at least sixty (60) days prior to that change becoming effective. This notice shall inform the Township of the intended transfer of control of the solar energy collector system or the underlying property, and shall include a copy of the instrument or agreement effecting that transfer. Such an instrument or agreement shall include an express statement that the new owner or operator of the solar energy collector system or the underlying property shall not be permitted to operate that system until compliance with the terms of this Ordinance, including requirements for continuing security and escrow funds, has been established.
- (y) **CONTINUING SECURITY:** If any Large Solar Energy System is approved for construction under this Section, Applicant shall post decommissioning security prior to the start of construction (in a mutually agreed upon form) for an amount necessary to accomplish the work specified in the decommissioning plan as agreed upon by the Township and Applicant. The amount shall be reasonably sufficient to restore the property to its previous condition prior to construction and operation of the Large Solar Energy System. The Applicant shall provide at least two (2) cost estimates from qualified contractors for full removal and disposal of equipment, foundations, and structures associated with the systems. Such financial security shall be kept in full force and effect during the entire time that the Large Solar Energy System exists or is in place, and such financial security shall be irrevocable and non-cancelable.
- (1) **Continuing Obligations:** Failure to keep any required financial security in full force and effect at all times while a Large Solar Energy System exists or is in place shall constitute a violation of the Special Land Use and this Ordinance, and will subject the Large Solar Energy System Applicant, owner and operator to all

remedies available to the Township, including any enforcement action, civil action, request for injunctive relief, and revocation of the Special Land Use.

- (z) OTHER REQUIREMENTS: Each Large Solar Energy System shall also comply with all applicable federal, state and county requirements, in addition to other applicable Township Ordinances. [New section 3.28 Ord. # 2021-04, effective 12/10/2021]

### Section 3.29 **FARM LABOR HOUSING**

Farm labor housing is allowed as either a primary or accessory use in the Exclusive Agricultural zoning district. In addition, the following specific standards, requirements and conditions shall also apply:

- (a) Farm labor housing is required to comply with the Michigan Public Health Code being Act 368 of the Public Acts of Michigan of 1978, as amended, including any rules promulgated pursuant thereto.
- (b) Occupants of the farm labor housing must be employed for farm or agricultural labor. Members of a qualifying occupant's immediate family may also reside in the farm labor housing with the working occupant even if those family members are not employed for farm or agricultural labor.
- (c) Mobile homes may be used to provide such housing, but must meet the size limitations of the State of Michigan and as provided in subsection G hereof. There shall be no more than 5 mobile homes per lot.
- (d) Farm labor housing shall not be placed within 100 feet of a property line not adjacent to a public street and must be at least 75 feet from the public street right-of-way on which the property fronts. These limitations as to distance from a property line shall not apply to an area presently and lawfully used for farm labor housing at the adoption of this Section 3.29, but in no case will an existing area used for farm labor housing be allowed to expand closer to any property line, which is within 100 feet.
- (e) Farm labor housing may be permitted on a lot which contains a minimum of five (5) acres and which complies with all other requirements of this Section 3.29. For a principal use, such lot shall be adjacent to a lot being actively farmed and both lots shall be under the same or substantially similar ownership.
- (f) Farm labor housing (and occupancy) within the Agricultural zoning district shall not exceed 100 persons per lot (as the lot existed as of May 5, 2022). However, the 100-person occupancy limit per lot contained in this Subsection (f) may be varied by the Planning Commission to allow more farm labor workers inhabitation or occupancy on a particular lot via a special land use approval utilizing the special land use

standards contained in Article 17 of this Ordinance together with the application of all of the following additional standards:

- (1) The landowner is actively engaged in substantial commercial farming within Casnovia Township.
- (2) Whether the consolidation of new or expanded farm labor housing on the lot which is the subject of the special land use request would help preserve prime and productive farm land on another lot or lots elsewhere within the Township owned by the same landowner involved which would or could otherwise be developed for farm labor housing.
- (3) Will consolidating new or expanded farm labor housing and allowing more farm labor workers to inhabit or occupy the lot for which the special land use is being requested result in a more efficient, safe and reasonable location for such occupancy of farm labor workers than would multiple new or expanded farm labor housing facilities on other separate lots owned by the landowner involved within the Township.
- (4) Such consolidation is reasonably necessary for the operation of one or more farms within Casnovia Township.

In deciding whether special land use will be approved for farm labor housing on a lot to exceed 100 persons, the Planning Commission shall also consider

- i. Whether the farm labor housing facilities will be partially or fully screened from view by trees or topography from all adjoining or nearby public roads and houses on other lots.
  - ii. Any recommendations made by the Casnovia Township Fire Chief or Fire Department.
  - iii. Any potential noise that may be caused by the occupants of the farm labor housing facility or vehicles or equipment associated with such housing.
- (g) Minimum dwelling size requirements and density for farm labor dwellings shall fully comply with any applicable Federal and State of Michigan laws and requirements.
  - (h) This Section 3.29 shall not apply to a situation involving a single family in one lawful single-family dwelling on a lot where one or more members of the family are farm or migrant laborers.
  - (i) This Section 3.29 applies where two or more farm labor families reside (whether seasonally, temporarily or permanently) on the same lot. Where two or more farm

labor families reside (whether seasonally, temporarily or permanently) on the same lot, it constitutes a multi-family use and activity.

- (j) If any farm labor housing is abandoned or is used for more than 60 months for housing other than farm labor, the housing or dwelling and related structures shall be fully removed. *[New section 3.29 Ord. # 2022-03, effective 06/13/2022]*

**Section 3.30. PONDS AND ARTIFICIAL BODIES OF WATER.**

No pond or artificial body of water, excluding ponds for koi, goldfish or any other decorative landscape pond containing an impermeable liner or Swimming Pools as defined by this Ordinance, shall be dug, created, or expanded unless approved with a zoning permit subject to the following:

- (a) A pond shall be permitted within all zoning districts.
- (b) A pond is defined as a body of water under five acres in area.
- (c) The pond shall be installed for recreation, pleasure, or agricultural uses only. The creation of any ponds for the purpose and result of peat, earth, gravel, clay, topsoil, stone or other soils or material extraction shall be regulated under Section 4.02.
- (d) A pond may be considered as a principal or accessory use.
- (e) At a minimum, a pond shall comply with all the yard requirements for the zoning district in which it is located, except that any pond used as a farm manure lagoon shall not be located less than three hundred (300) feet from any lot lines or road right-of-way lines.
- (f) The slopes of the banks or sides of the pond shall be constructed so that for each one (1) foot of rise there shall be a minimum of three (3) feet of run for at least one quarter (1/4) of the circumference of the pond. This minimum slope angle must be maintained and extended into the pond water to a depth of five (5) feet.
- (g) Ponds shall contain a minimum depth of twelve (12) feet.
- (h) Application for approval of a zoning permit for a pond shall include:
  - a. The name of the person who is or will be the owner of the pond.
  - b. The size, depth, slope, and water capacity of the pond.
  - c. Source of water and method of water discharge.
  - d. The method of filtration and treatment of the water, if required.
  - e. A plot plan, drawn to scale, of the land on which the pond is to be located, showing the following:

- i. Lot lines.
  - ii. Location and dimensions of the pond.
  - iii. Location of all buildings on the premises and their relation to the pond.
  - iv. Location of any topsoil, sand or other material excavated from the land and their intended use.
- (i) A pond may be located so as to be shared by more than a single lot or parcel by extending across common property lines, provided that the perimeter of such pond meets all required yard or other setback requirements from all property lines and structures. The Applicant and/or owners of a pond that is shared by more than a single lot or parcel shall provide to the Township a maintenance agreement, recorded at the Muskegon County Register of Deeds, which shall provide for the perpetual private (non-public) maintenance of the pond to a necessary and reasonable standard to serve the parties having an interest in the pond. The maintenance agreement shall minimally contain the following provisions:
- (1) A method of appropriating the costs of maintenance and improvements in order to keep the pond in a reasonably good and usable condition. For the purposes of this section, "maintenance" and "improvements" shall include but not be limited to the prevention of bank erosion, lateral stabilization, clean out of the build-up of sediment, proper water filtration and treatment and safety precautions.
  - (2) A provision that the owners shall refrain from prohibiting, restricting, limiting or in any manner interfering with the normal use by any other owner. Normal use shall include use by family or guests.
- (j) No pond shall be constructed, installed, or maintained which either causes or contributes to the erosion of any adjacent, abutting, or nearby lands.
- (k) In the case of farm manure lagoons, no permit shall be issued unless the Applicant demonstrates compliance with the permitting requirements of either the Michigan Department of Agriculture, the Michigan Department of Natural Resources, the Michigan Department of Environment, Great Lakes and Energy, or other successor agency, for discharge into surface and/or groundwater.

### **3.31 ADULT ENTERTAINMENT ESTABLISHMENT.**

- (a) Description and Purpose. It is recognized that there are some uses which, because of their very nature, have serious objectionable operational characteristics, particularly when several of them are concentrated in near proximity to a residential zone, thereby having a deleterious effect upon the adjacent areas. Special regulation of these uses is necessary to ensure that these adverse effects will not contribute to the blighting or downgrading of the surrounding neighborhood. These special regulations are itemized in this Section. These controls are for the purpose of preventing the concentration of these uses within any one area, or to prevent

deterioration or blighting of a nearby residential neighborhood. These controls do not legitimize activities which are prohibited in other sections of this Ordinance.

Uses subject to these controls are as follows:

- \* Adult arcades
- \* Adult bookstores or video stores
- \* Adult cabarets
- \* Adult entertainment booking agencies
- \* Adult motels
- \* Adult motion picture theaters
- \* Adult theaters
- \* Dating services
- \* Escorts
- \* Escort agencies
- \* Massage establishments, massage parlors, and massage schools
- \* Nude model, artist and photography studios
- \* Sexual encounter centers

(b) Definitions. As used in this ordinance, the following terms shall have the indicated meanings.

(1) *Adult Arcades*: A commercial establishment that offers coin-operated (or operation by any other form of consideration) electronically, electrically, or mechanically controlled still or motion picture machines, projectors, video or laser disc players, or other image-producing devices to show images to five (5) or fewer persons per machine at any one time, and where the images so displayed are distinguished or characterized by the depicting of specified anatomical areas or specified sexual activities.

(2) *Adult Bookstores or Adult Video Stores*: A commercial establishment that has as a substantial or significant portion of its stock in trade, and as one of its principal business purposes offers for sale or rental for any form of consideration, any one or more of the items set forth below. A commercial establishment may have other principal business purposes that do not involve offering for sale or rental the material identified below and still be categorized as an adult bookstore or adult video store.

- \* Books, magazines, periodicals or other printed matter, photographs, films, motion pictures, video cassettes or video reproductions, slides, or any other

visual representations or media which depict or describe specified anatomical areas or specified sexual activities; or

- \* Instruments, devices, or paraphernalia that are designed for use in connection with specified sexual activities.

(3) *Adult Cabaret*: A nightclub, bar, restaurant, or similar commercial establishment that regularly features:

- \* Persons who appear in a state of nudity;
- \* Live performances that are characterized by the exposure of specified anatomical areas or by specified sexual activities;
- \* Films, motion pictures, video cassettes, slides, other photographic reproductions or visual media that are characterized by the depiction or description of specified anatomical areas or specified sexual activities; or
- \* Persons who engage in lewd, lascivious or erotic dancing or performances that are intended for the sexual interests or titillation of an audience or customers..

(4) *Adult Entertainment Booking Agency*: A business engaged in for financial remuneration, either directly or indirectly, wherein the owner, operator or agent books performances for dancers, comedians, musicians, entertainers or burlesque performers, taking a fee, commission or percentage of any money from the patron or performer for services rendered, when the performances are characterized by exposure of specified anatomical areas or by specified sexual activities.

(5) *Adult Motel*: A hotel, motel or similar commercial establishment that does any of the following:

- \* Offers accommodations to the public for any form of consideration and provides patrons with closed-circuit television transmissions, films, motion pictures, video cassettes, slides, other photographic reproductions or visual media that are characterized by the depiction or description of specified anatomical areas or specified sexual activities; or has a sign visible from the public right of way that advertises the availability of any of the above; or
- \* Offers a sleeping room for rent for a period of time that is less than twelve (12) hours; or
- \* Allows a tenant or occupant of a sleeping room to sub-rent the room for a period of time that is less than twelve (12) hours.

- (6) *Adult Motion Picture Theater*: A commercial establishment that, for any form of consideration, regularly shows films, motion pictures, video cassettes, slides, other photographic reproductions or visual media, that are characterized by the depiction or description of specified anatomical areas or specified sexual activities.
- (7) *Adult Theater*: A theater, concert hall, auditorium, or similar commercial establishment that regularly features a person or persons who appear in a state of nudity or live performances that are characterized by exposure of specified anatomical areas or by specified sexual activities.
- (8) *Dating Service*: A business engaged in for financial remuneration, either directly or indirectly, where arrangements are made to match a person of the same or opposite sex to a patron or patrons, for social or entertainment purposes, either on or off the premises of the dating service.
- (9) *Escort*: A person who, for consideration, agrees or offers to act as a companion, guide, or date for another person, or who agrees or offers to privately model lingerie or to privately perform a striptease for another person.
- (10) *Escort Agency*: A person or business who furnishes, offers to furnish, or advertises the furnishing of escorts for a fee, tip, or other consideration.
- (11) *Massage*: The performance of manipulative exercises upon the human body of another by rubbing, kneading, stroking or tapping with the hand or hands, or with any mechanical or bathing device, with or without supplementary aids, for non-therapeutic purposes. The systematic and scientific manipulation of the soft tissues of the human body by a health care professional for therapeutic and/or rehabilitative purposes shall be considered a therapeutic massage and not restricted by this Section.
- (12) *Massage Parlor*: Any commercial establishment where non-therapeutic massage is made available for any form of consideration.
- (13) *Massage School*: Any place, establishment or facility which provides instruction in the theory, method and practice of non-therapeutic massage.
- (14) *Nude Model Studio*: Any place where a person who displays specified anatomical areas is provided in order to be observed, sketched, drawn, painted, sculptured, photographed, or similarly depicted by other persons who pay money or any form of consideration, but not including:
  - \* An educational institution funded, chartered, licensed or recognized by the State of Michigan; or

- \* A private artist's studio where the private artist employs or contracts with the model to be observed and depicted solely by the private artist.
- (15) *Nudity or a State of Nudity*: Knowingly or intentionally displaying in a public place, or for payment or promise of payment by any person including, but not limited to, payment or promise of payment of an admission fee, any individual's genitals or anus with less than a fully opaque covering, or a female individual's breast with less than a fully opaque covering of the nipple and areola. Public nudity does not include:
- \* A woman's breastfeeding of a baby whether or not the nipple or areola is exposed during or incidental to the feeding;
  - \* Material as defined in section 2 of Act No. 343 of the Public Acts of 1984, as amended, being MCL 752.362, or any similar successor statute; or
  - \* Sexually explicit visual material as defined in section 3 of Act No. 33 of the Public Acts of 1978, as amended, being MCL 722.673, or any similar successor statute.
- (16) *Public Place*: Any real property or an appurtenance to real property that is owned or leased by the State of Michigan, any local unit of government of the State of Michigan, a public agency, or by a college or university of the State of Michigan and may include a structure, enclosure, facility, or complex, including a court, mall, park, or other area, feature, or element; a public place shall also mean a business or an educational, refreshment, entertainment, recreation, health, or transportation facility, or institution of any kind, whether licensed by any agency of government or not, whose goods, services, facilities, privileges, advantages, or accommodations are extended, offered, sold, or otherwise made available to the public.
- (17) *Sexual Encounter Center*: A commercial establishment that, as one of its principal business purposes, offers for any form of consideration:
- \* Physical contact in the form of wrestling or tumbling between persons of the opposite sex; or
  - \* Activities between male and female persons or persons of the same sex when one or more of the persons is in a state of nudity.
- (18) *Specified Anatomical Areas*:
- \* Less than completely and opaquely covered human genitals, pubic region, buttock, anus and female breast below a point immediately above the top of the areola; or

- \* Human male genitals in a discernible turgid state, even if completely and opaquely covered.

(19) Specified Sexual Activities: Include any of the following:

- \* The erotic fondling or erotic touching of human genitals, pubic region, buttocks, anus, or female breasts;
- \* Sex acts, normal or perverted, actual or simulated, including, but not limited to, intercourse, oral copulation, sodomy, and/or masturbation;
- \* Sexual arousal or gratification using animals or violence, actual or simulated;
- \* Excretory functions as part of or in connection with any of the activities set forth above.

(c) Requirements for Approval. An adult entertainment establishment shall be permitted only as a special use and only if the following standards are satisfied.

- (1) The proposed use shall be located only within a I-1 Industrial District.
- (2) The proposed use shall not be located on a parcel that is within one thousand (1000) feet of another adult entertainment establishment.
- (3) The proposed use shall not be located within seven hundred fifty (750) feet of a single-family, two-family, or multiple-family dwelling on land in the agricultural or any residential zoning district or approved as a planned unit development for residential purposes.
- (4) The proposed use shall not be located within seven hundred fifty (750) feet of any Township, County or State Park; school; library; licensed childcare facility; playground; church or place of worship.

For purposes of subsections (2), (3), and (4) above, the distance shall be measured in a straight line from the nearest building or structure on the parcel on which the proposed use is to be located to the nearest building or structure on the land containing a use specified in subsections (2), (3), or (4) above.

- (5) The proposed use shall not be located within any principal or accessory building or structure already containing another adult entertainment establishment.
- (6) The proposed use shall conform to all requirements of the I-1 Industrial District.

- (7) The proposed use shall be in compliance with all other ordinances of the Township and with all statutes, laws, rules and regulations of the County, State and Federal government and, to the extent required, all governmental approvals must be obtained.
- (8) The outdoor storage of garbage and refuse shall be contained, screened from view and located so as not to be visible from neighboring properties or the adjacent right-of-way of a public street or private street.
- (9) Any sign or signs proposed for the proposed use shall comply with the provisions Section 3.21 of this Ordinance; may not include photographs, silhouettes, drawings, or pictorial representations of specified anatomical areas, specified sexual activities or obscene representations of the human form; and may not include animated or flashing illumination.
- (10) Entrances to the proposed use must be posted on both the exterior and interior walls, in a location clearly visible to those entering and exiting the business, and using clearly marked lettering no less than two (2) inches in height stating that:
  - (1) "Persons under the age of 18 are not permitted to enter the premises," and
  - (2) "No alcoholic beverages of any type are permitted within the premises unless specifically allowed pursuant to a license duly issued by the Michigan Liquor Control Commission."
- (11) No product or service for sale or gift, or any picture or other representation of any product or service for sale or gift, shall be displayed so as to be visible by a person of normal visual acuity from the nearest adjoining right-of-way of a public street or private street or a neighboring property.
- (12) Hours of operation shall be limited to 10:00 AM to 10:00 PM, Monday through Saturday. All adult entertainment establishments shall remain closed on Sundays and legal holidays.
- (13) All off-street parking areas shall comply with this Ordinance and shall be illuminated after sunset during all hours of operation of the sexually oriented business, and until one (1) hour after the business closes. The illumination shall be designed to provide a minimum level of brightness of one (1) foot candle, with a 3:1 uniformity ratio. The illumination shall not reflect on and shall be screened from adjoining properties.
- (14) Any booth, room or cubicle available in any sexually oriented business, except an adult motel, that is used by patrons for the viewing of any entertainment characterized by the showing of specified anatomical areas or specified sexual activities shall:

- \* Be handicap accessible to the extent required by law;
- \* Be unobstructed by any floor, lock or other entrance and exit control device;
- \* Have at least one (1) side totally open to a public, lighted aisle so that there is an unobstructed view of any occupant at all times from the adjoining aisle;
- \* Be illuminated such that a person of normal visual acuity can, by looking into the booth, room or cubicle from its entrance adjoining the public lighted aisle, clearly determine the number of people within; and
- \* Have no holes or openings in any side or rear walls not relating to utility, ventilation or temperature control services or otherwise required by any governmental building code authority.

(c) Special Use Process. Any special use application for an adult entertainment establishment shall be processed under the provisions of Articles 17 and 19 of this Ordinance.

(d) Conditions. The Township Board may impose reasonable conditions in conjunction with the approval of a special use permit for a sexually oriented business. The conditions imposed shall be limited to conditions necessary to ensure that the sexually oriented business will not be unreasonably detrimental to the public health, safety, or general welfare of the Township; nor unreasonably injurious to the use and enjoyment of other property in the immediate vicinity for the purposes already permitted; nor unreasonably impede the normal and orderly development and improvement of the surrounding property for uses permitted under this Ordinance.

(e) Decision. The Township Board shall incorporate its decision in a written statement containing the conclusions that specify the factual basis and reasons for the decision and any conditions imposed.

## **ARTICLE 4**

### **110.400 GENERAL ENVIRONMENTAL PROVISIONS**

#### **110.401 Drainage courses.**

Section 4.01. The provisions of this section apply to drainage courses.

The following conditions shall apply:

- a. No structures may be built in such drainage courses.
- b. Such courses may not be filled, and the land-owner shall keep same free of any debris, nor shall he allow any organic or inorganic material to accumulate or to obstruct the flow of water.
- c. Such courses shall not be altered or changed in any way unless the landowner first obtains a site plan approval by the Planning Commission. In addition to the requirements of this section, the Planning Commission may use the requirements of Special Use Permits, as a guide in their determination. The Township Board shall also find the following as a condition of granting such permit that the alteration will not:
  - (1) Impede the flow of water, or cause ponding.
  - (2) Cause erosion.
  - (3) Cause loss of flooding water back-up space.
  - (4) Cause diversion of the course of water from the applicant's property to another location.
  - (5) Cause water back-up to public road ditches, or other private property.
  - (6) Cause loss of flood-impeding capacity.
  - (7) Cause loss of area for effluent cleansing.
- d. Such approval shall not be necessary for landscaping, stabilization, terracing of embankments, construction of foot bridge across such courses, and the drawing of such drainage course to create artificial ponds; if, in the opinion of the Zoning Administrator, such proposed activity will not reduce the capacity of the course to fulfill its natural functions or adversely affect property up or downstream.

#### **110.402 Sand and gravel mining and related land use activities and structures; scope, purpose and intent.**

Section 4.02. No sand, gravel, mining or excavation shall be permitted except by special use permit issued by the Administrator, after

application has been made and approved by the Casnovia Township Board. The application shall include a development plan, operational statement and rehabilitation plan. It shall first be submitted to the Planning Commission for review and recommendation to the Township Board. The following information shall be submitted:

a. *Site plan.* A site plan with seven (7) copies which shall include the following information:

- (1) North point, scale and date.
- (2) Extent of the area to be excavated.
- (3) Location, width and grade of all easements or rights-of-way on or abutting the property.
- (4) Location of all structures on the property.
- (5) Location of all areas on the property subject to inundation or flood hazard, and the location, width and directions of flow of all watercourses, and flood control channels that may be affected by the excavation.
- (6) U.S. Geological Survey –geodetic survey benchmark.
- (7) Existing elevations of the total property at intervals of not more than one hundred (100) feet in both north-south and east-west directions and existing elevations of abutting properties at intervals of not more than one hundred (100) feet around the perimeter of the property and one hundred (100) feet from property lines. This requirement can be modified by the Township Board on applications for mining, if the size of the site and uniformity of the grade is such that this information is not necessary in the review process of the application.
- (8) Typical cross-sections, showing the extent of over-burden, extent of sand and gravel deposits and the water table.
- (9) Processing and storage areas.
- (10) Proposed fencing, gates, parking and signs.
- (11) Ingress-egress roads, plus on-site roads and proposed surface treatment and means to limit dust.
- (12) A map showing access routes between the property and the nearest arterial road.
- (13) Areas to be used for ponding.

b. *Operational statement.* An operational statement which shall include the following information:

- (1) The approximate date of commencement of the excavation and the duration of the operation.
- (2) Proposed hours and days of operation.
- (3) Estimated type and volume of the excavation.
- (4) Method of extracting and processing, including the disposition of over-burden or topsoils.
- (5) Equipment proposed to be used in the operation of the

excavation.

(6) Operating practices proposed to be used to minimize noise, dust, air contaminants and vibration.

(7) Methods to prevent pollution of surface or underground water.

c. *Rehabilitation plan.* A rehabilitation plan which shall include:

(1) A statement of planned rehabilitation , including methods of accomplishment, phasing and timing.

(2) A plan indicating: the final grade of the excavation; any water features included in the rehabilitation and methods planned to prevent stagnation and pollution; landscaping or vegetative planting; and areas of cut or fill. This plan, if clearly delineated, may be included with the site plan. For quarry application, the final grade shall mean the approximate planned final grade.

(3) A phasing plan, if the excavation of the site is to be accomplished in phases. This plan shall indicate the area and extent of each phase and the approximate timing of each phase.

d. The method of disposing of any equipment or structures used in the operation of the excavation upon completion of the excavation.

e. The name, address and signature of the property owners and applicant.

f. A written legal description or record of survey of the property.

g. A bond, cash deposit or deposit of negotiable securities and public liability insurance shall be provided to ensure conformance to Township operational and reclamation standards.

h. In agricultural areas, a soil report, prepared by a person qualified to analyze agricultural soils, shall be required for all proposals where the topsoil is not to be replaced upon completion of the excavation.

i. *Review standards for approval.* The Planning Commission and Township Board may consider the following factors in their review of the permit application:

(1) The need for the removal, and alternate solutions not requiring removal.

(2) The impact of the removal process and methods of removal on adjoining areas.

(3) The extent and amount of removal of valuable surface topsoil, and destruction of land uses by the removal.

(4) The increased hazards to neighbors, water, land or air.

- (5) The proposed plan complies with existing applicable County and State waste management plans and standards.
  - (6) Whether the spirit and intent of the objectives of this Zoning Ordinance would be preserved or promoted.
- j. *Filling of land.* No use of land for filling with borrowed fill sand, gravel, cinders, industrial waste or any material of any form or nature shall be allowed without a fill permit issued by the Zoning Administrator and other local or State agency as required.
- k. *Application.* Every application for a permit to till land shall be accompanied by a specification sheet showing the grade level proposed for the fill, a statement as to the materials to be used, the period of time over which the fill will be brought in and the contour of the lot after the proposed fill is completed. The application will be made in writing to the Administrator.
- l. *Permit to fill.* The Zoning Administrator will issue the permit to fill land, after he has determined:
- (1) That such filing will not cause surface water to collect or to run off onto adjoining lands contrary to normal and natural drainage.
  - (2) That such fill material will not unreasonably cause blowing dust, grime, fumes or odors.
  - (3) That such fill will not decay or rot in such a manner as to cause holes or soft areas to develop in the lands so filled.
  - (4) That, upon completion of such fill, the property will be left in such a condition that it may be properly used for the use designated for the area in the Zoning Ordinance and maps.
  - (5) That such fill shall not operate to inhibit light and air to the adjoining properties.
  - (6) That such filling operations will not be conducted before sunrise or after 8:00 P.M., local time.
  - (7) That the transportation of such fill material will be made in trucks or vehicles properly suited to such transport so that it will not be spread upon the highways and roads to the Township.
  - (8) That such fill will not cause any hazard of fire and that combustible materials shall not become any part of the fill material.
  - (9) That the filling will be carried out under the terms and conditions above set forth, and that the Administrator may, if he is concerned about the applicants fulfilling the above conditions, require a performance bond in favor of the Township and conditioned upon the applicant faithfully carrying out all of the terms and conditions of the permit.

Section 4.03. This overlay zone is intended to promote public health, safety and general welfare and minimize public and private losses due to flood conditions. It is designed to restrict or prohibit those uses which are dangerous to health, safety and property due to water or erosion in flood heights or velocities. These provisions require that uses vulnerable to floods, including facilities which serve such uses, be protected against flood damage at the time of initial construction.

- A. *Area affected.* The area affected by this overlay zone includes all areas in the Township of Casnovia designated by the Federal Insurance Administration as areas of special flood hazard.
- B. *General zone requirements.* All new construction and substantial improvement to structures shall be constructed so that the lowest floor, including basement, shall be at or above base flood elevation, together with attendant utilities and sanitary facilities may be designed so that below the base flood elevation the structure is watertight with walls substantially impermeable to the passage of water and with structural components having the capability of resisting hydrostatic and hydrodynamic loads and effects of buoyancy and shall:
  - 1. Be designed (or modified) to resist flotation, collapse or lateral movement of the structure.
  - 2. Be constructed with materials and utility equipment resistant to flood damage.
  - 3. Be constructed by methods and practices that minimize flood damage.
- C. *Warning and disclaimer of liability.* The degree of flood protection required by this Ordinance is considered reasonable for regulatory purposes and is based on scientific and engineering considerations. Larger floods can and will occur on rare occasions. Flood heights may be increased by manmade or natural causes. This Ordinance does not imply that areas outside the flood hazard zone boundaries or land uses permitted within such districts will be free from flooding or flood damages. This Ordinance shall not create liability on the part of the Township of Casnovia or by any officer or employee thereof for any flood damages that result from reliance on this Ordinance or any administrative decision lawfully made thereunder.
- D. *Statements required.* Prior to the issuance of a building permit, for structures to be located within a flood hazard zone, an applicant shall first be required to sign a statement he/she has been informed of the hazard and his/her construction will not give rise to a claim against the Township of Casnovia for having authorized issuance of a building permit.

- E. *Utilities protection.* The Muskegon County Health Department shall require new or replacement water supply systems and/or sanitary sewage systems to be designed to minimize or eliminate infiltration of flood waters into the system and discharges from the systems to be located so as to avoid impairment of them or contamination from them during flooding.
- F. *Interpretation.* Where interpretation is needed as to the exact location of the boundaries of the areas of special flood hazards (for example, where there appears to be a conflict between a mapped boundary and actual field conditions), the Zoning Administration shall make the necessary interpretation. The person contesting the location of the boundary shall be given reasonable opportunity to appeal the interpretation as provided in this Ordinance.
- G. *Nonresidential structures.* A building permit may not be issued for construction or extension of a nonresidential structure in a flood hazard zone unless a site plan has been approved by the Casnovia Township Board. The site plan shall first be submitted to the Planning Commission for review and recommendation to the Township Board. In addition to the applicable requirements of Article 19 (Site Plan Review), the Township Board shall also require the following information and conditions be met before approval is granted:
1. *Application for site plan approval.* The application for site plan approval shall contain the following information and any other information requested by the Township Board:
    - a. A map in duplicate, drawn to scale showing the curvilinear line representing the regulatory flood elevation, dimensions of the lot, existing structures and uses on the lot and adjacent lots, soil type, dunes and natural protective barriers, if applicable, existing flood control and erosion control works, existing drainage elevations and ground contours, location and elevation of existing street, water supply and sanitary facilities, other pertinent information.
    - b. A preliminary plan showing the approximate dimension, elevation and nature of the proposed use, amount, area and type of proposed fill; area and nature of proposed grading or dredging; proposed alteration of dunes, beaches or other natural protective barriers, if applicable; proposed flood protection or erosion control works; proposed drainage facilities; proposed roads, sewers, water and other utilities;

specifications for building construction and materials included in the flood proofing

2. *Technical assistance in evaluating project.* The Township Board shall obtain assistance of the County Engineer for technical assistance in evaluating the proposed project in relation to flood heights and velocities, threatened erosion or wave action, the adequacy of the plans for flood erosion protection, the adequacy of drainage facilities and other technical matters.
3. *Determining flood hazard.* The Township Board shall determine the specific flood or erosion hazard at the site and shall evaluate the suitability of the proposed use in relation to the flood hazard, and if a permit is to be issued may attach appropriate conditions. In passing upon such application, the Township Board shall consider the technical evaluation of the engineer, all relevant facts, and standards specified in other sections of this Ordinance.

## ARTICLE 5

### 110.500 ZONING DISTRICTS AND MAP

#### 110.501 Zoning Districts.

Section 5.01. For the purpose of this Ordinance, Casnovia Township is divided into the following zoning districts:

- a. R-1 Single Family Residential District.
- b. R-2 Residential/Agricultural District.
- c. PURD Planned Unit Residential Development District.
- d. A-1 Exclusive Agricultural District.
- e. A-2 Intensive Agricultural District.
- f. A-3 Agricultural Industry/Business District.
- g. C-1 Commercial District.
- h. I-1 Industrial District.

#### 110.502 Zoning district map.

Section 5.02. The location and boundaries of the zoning districts are hereby established as shown on the map entitled “Zoning District Map” on file with the Township Clerk. The “Zoning District Map”, together with all information shown thereon, shall be as much a part of this Ordinance as if fully set forth and described herein.

#### 110.503 Resolution of zoning district boundaries.

Section 5.03. Where uncertainty exists with respect to the boundaries of the various districts as shown on the Zoning District Map, the following rules shall apply:

- a. Boundaries indicated as approximately following the centerlines of streets, highways or alleys shall be construed to follow such centerlines.
- b. Boundaries indicated as approximately following platted lot lines shall be construed as following such lot lines.
- c. Boundaries indicated as approximately following Township limits shall be construed as following Township limits.
- d. Boundaries indicated as parallel to or extensions of features indicated in subsections a through c above shall be so construed.

Where any uncertainty exists as to the exact location of a zoning district boundary line, the Township Planning Commission, upon written application or upon its own initiative, shall determine the location of such boundary line. Any such determination so made by the Planning

Commission shall be forwarded to the Township Zoning Administrator who shall thereupon record the determination upon the “Zoning District Map”.

## ARTICLE 6

### 110.600 SINGLE FAMILY RESIDENTIAL DISTRICT (R-1)

#### 110.601 Purpose.

Section 6.01. The R-1 District provides for those areas where single family residences of limited lot areas exists. It is intended to provide areas protected under this Ordinance as residential living areas free of incompatible uses and assuring adequate light and yard areas.

#### 110.602 Principal uses permitted.

Section 6.02. No building or land shall be used for any purposes except the following in the R-1 District:

- a. Single family residential development.
- b. Home occupation subject to the provisions of Sections 2.21 and 3.11.
- c. Subterranean or underground homes are allowed subject to the provisions of Section 3.08.
- d. Mobile homes subject to the provisions of Section 3.10.
- e. Public parks, playgrounds, recreation areas, schools and churches.

#### 110.603 Special permit uses.

Section 6.03. Subject to the conditions and limitations found in Article 17:

- a. Utility buildings and facilities.

#### 110.604 Accessory uses.

Section 6.04. Those buildings, structures and uses customarily accessory to those principal and special uses as set forth above are permitted subject to the provisions of Article 14.

#### 110.605 Additional requirements.

Section 6.05. Height, lot area, frontage width, yard area and floor area requirements and restrictions shall further be complied with as set forth in Article 16.

## ARTICLE 7

### 110.700 RESIDENTIAL AGRICULTURAL DISTRICT (R-2)

#### 110.701 Description of district.

Section 7.01. The purpose of the “R-2” District is to permit the utilization of relatively small quantities of land in predominantly agricultural areas for rural residential use. It is not intended that this district be utilized to accommodate residential subdivisions as defined in the Michigan State Subdivision Control Act of 1967, as amended.

#### 110.702 Principle uses permitted.

Section 7.02.

- a. Any non-intensive farm or agricultural activities including stock nurseries, except that for the raising or keeping of animals or livestock whether for profit or pleasure, the minimum lot area requirements shall be five (5) acres and a width of not less than three hundred (300) feet for the first two (2) head of livestock. An additional one and a half (1½) acres shall be required for each head of livestock beyond two (2). There shall be a maximum number of twelve (12) livestock kept on parcels of twenty (20) acres or more.
- b. The sale of farm or dairy produce which has been raised on the farm from which it is to be sold.
- c. Existing one and two family farm dwellings.
- d. Single family, non-farm dwellings, subject to the density limitations and provisions of Article 16.
- e. Home occupations.
- f. Publicly owned and operated buildings and uses including community buildings and public parks, playgrounds and other recreational areas.
- g. Signs, when in accordance with the provisions of this Ordinance.
- h. Accessory uses or buildings, when in accordance with the provisions of Article 14.

#### 110.703 Special permit uses.

Section 7.03. Subject to the conditions and limitations found in Article 17.

a. Public utility buildings and structures necessary for the service of the community except that:

- (1) There is no zoning restriction for utilities to be located in public streets or public rights-of-way.
- (2) Public utility activities of an industrial character such as repair and maintenance yards, storage facilities, or activities which generate electronic interference are prohibited.

b. Churches, cemeteries, schools.

c. Golf courses.

d. Riding stables, kennels.

e. Commercial Camp Grounds,

1. May be permitted when in full compliance with campground requirements of the Michigan Department of Public Health, adequate water supply and restrooms are provided. The camp ground cannot be located within 100 feet of the 100 year flood plain or a regulated wetland or water course.
2. Hiking, bicycle and cross country ski trails may be permitted upon a finding by the Planning Commission that location, grades and trail use will not have a significant environmental impact or negative impact on neighboring property owners.
3. Motorized recreational vehicles are not permitted, except for use in controlling or policing the campground or trail.
4. Minimum lot size for a commercial campground facility shall be (20) acres. The lot shall provide direct vehicular access to a paved public street or road.
5. Public restrooms, housed in all-weather structures, containing adequate water outlet, waste container, toilet and shower facilities shall be provided so long as the restrooms and facilities meet State and County Public Health requirements and standards.
6. Laundry facilities are prohibited.
7. Each lot shall provide hard-surfaced, dust-free vehicle parking areas for site occupant and guest parking. Such parking area shall be located within four hundred (400) feet of the site it is intended to serve (except in the case of sites specifically designated only for tent camping).

8. Each site shall contain a minimum of fifteen hundred (1,500) square feet. Each site shall be set back from any right-of-way or property line at least seventy five (75) feet.
  9. Each travel trailer site shall have direct access to a hard-surfaced, dust-free roadway of at least twenty four (24) feet in width for two-way traffic and twelve (12) feet in width for one-way traffic. Parking, shall not be allowed on any roadway. Sites specifically designated for, and only used for, tent camping, need not have direct vehicular access to any street or road.
  10. Any open drainage ways must have seeded banks sloped at least 3:1 and designed to properly drain all surface waters into the County drain system, subject to approval by the County Drain Commissioner.
  11. All sanitary facilities shall be designed and constructed in strict conformance to all applicable County health regulations.
  12. The development of the entire lot is subject to all applicable requirements of the Department of Natural Resources.
  13. A minimum distance of fifteen (15) feet shall be provided between all travel trailers and tents.
  14. Year round occupancy of any camp site is prohibited.
  15. Year round storage of Travel Trailers or campers is permitted.
- f. Recreational Facilities for public use.

**ARTICLE 7-A**

**110.7A00 RESIDENTIAL-ESTATE DISTRICT (R-3)**

**110.7A01 Purpose.**

Section 7A.01. The R-3 Residential-Estate District provides for large, estate-style single-family dwellings on large parcels of land. It is intended to provide areas for high quality, quiet living in a country atmosphere in areas not likely to be serviced by municipal sewer and water, and where the soils (because of excessive slopes or other factors) are not suitable for agricultural activities.

(Ord. No. 110-700-A effective 02/05/1992)

**110.7A02 Principal uses.**

Section 7A.02. No building or land shall be used for any purposes except the following in the R-3 District:

- a. Single family residential development.
- b. Home occupations subject to the provisions of Section 2.21 and 3.11.
- c. No animals except common household pets may be kept on the premises, and no more than 4 such animals in any combination.

(Ord. No. 110-700-A Effective 02/05/1992)

**110.7A03 Special Permit uses.**

Section 7A.03. Subject to the conditions and limitations found in Article 17:

- a. Utility buildings and facilities.

(Ord. No. 110-700-A effective 02/05/1992)

**110.7A04 Accessory Uses.**

Sec. 7A.04. Those buildings, structures, and uses customarily accessory to those principal uses as set forth above are permitted subject to the provisions of Article 14.

(Ord. No. 110-700-A eff. Feb. 5, 1992)

## ARTICLE 8

### 110.800 PLANNED UNIT RESIDENTIAL DISTRICT (PURD)

#### 110.801 Purpose and intent.

Section 8.01. This district shall allow a flexibility of and uses found in several districts, but it shall exclude all nonresidential uses.

#### 110.802 Principal uses permitted.

Section 8.02. None.

#### 110.803 Special permit uses.

Section 8.03. Subject to the conditions and limitations found in Article 17.

- a. All residential uses allowed in the residential districts.
- b. Multifamily housing.
- c. Condominium housing.

## ARTICLE 9

### 110.900 EXCLUSIVE AGRICULTURAL (A-1)

#### 110.901 Purpose.

Section 9.01. The purpose of the “A-1” District is twofold; first, to maintain, preserve and enhance prime agricultural lands which have historically exhibited high crop yields; second, the intent of the district is to allow maximum freedom of operations for agricultural pursuits and to protect such uses from encroachment of non-agricultural uses.

#### 110.902 Principal uses permitted.

Section 9.02.

- a. Any non-intensive farm or agricultural activities including stock nurseries, animal and livestock raising.
- b. The sale of farm or dairy produce which has been raised on the farm from which it is to be sold.
- c. Single family dwellings.
- d. Accessory uses or buildings, when in accordance with the provisions of Article 14.
- e. Home occupations.

(Ord. No. 100-900, 06-05-93)

- f. State licensed Migrant Labor Housing. Migrant Labor housing shall be permitted so long as a State License is obtained for any Migrant Labor Housing and so long as an informal site plan is provided to the Zoning Administrator.

#### 110.903. Special permit uses.

Section 9.03. Subject to the conditions and limitations found in Article 17.

- a. Intensive farming and agricultural operations as outlined in the “A-2” Intensive Agricultural District.
- b. Public utility buildings and structures necessary for the service of the community except that:

- (1) There is no zoning restriction for utilities to be located in public streets or public rights-of-way.
  - (2) Public utility activities of an industrial character such as repair and maintenance yards, storage facilities, or activities which generate electronic interference are prohibited.
- c. Veterinarian clinics and facilities for the care and/or boarding of animals including kennels.
  - d. Single-family non-farm dwellings, except in those situations in which the dwelling has been destroyed by fire or Act of God, when the replacement dwelling is of better or at least similar quality than the previous unit before it was destroyed. A special use permit shall also be waived in the event that a dwelling unit is being willfully removed in order to build a replacement that is of better quality. In both of these situations, all codes and conditions of this and other ordinances must be met.
  - e. Commercial greenhouses.  
(Ord. No. 110.903-A, effective Feb. 5, 1992)
  - f. Commercial Camp Grounds.
    - 1. May be permitted when in full compliance with campground requirements of the Michigan Department of Public Health, adequate water supply and restrooms are provided. The Campground may not be located within 100 feet of the 100 year flood plain or a regulated wetland or water course.
    - 2. Hiking, bicycle and cross country ski trails may be permitted upon a finding by the Planning Commission that location, grades and trail use will not have a significant environmental impact or negative impact on neighboring property owners.
    - 3. Motorized recreational vehicles are not permitted, except for use in controlling or policing the campground or trail.
    - 4. Minimum lot size for a commercial campground facility shall be twenty (20) acres. The lot shall provide direct vehicular access to a paved public street or road.
    - 5. Public restrooms, housed in all-weather structures, containing adequate water outlet, waste container, toilet and shower facilities shall be provided so long as the restrooms and facilities meet State and County Public Health requirements and standards.
    - 6. Laundry facilities are prohibited.
    - 7. Each lot shall provide hard-surfaced, dust-free vehicle parking areas for site occupant and guest parking. Such parking area shall be located within four hundred (400) feet of the site it is intended to serve (except in the case of sites specifically designed only for tent camping).

8. Each site shall contain a minimum of fifteen hundred (1,500) square feet. Each site shall be set back from any right-of-way or property line at least seventy five (75) feet.

9. Each travel trailer site shall have direct access to a hard-surfaced, dust-free roadway of at least twenty four (24) feet in width for two-way traffic and twelve (12) feet in width for one-way traffic. Parking, shall not be allowed on any roadway. Sites specifically designated for, and only used for tent camping, need not have direct vehicular access to any street or road.

10. Any open drainage ways must have seeded banks sloped at least 3:1 and designed to properly drain all surface waters into the County drain system, subject to approval by the County Drain Commissioner.

11. All sanitary facilities shall be designed and constructed in strict conformance to all applicable County health regulations.

12. The development of the entire lot is subject to all applicable requirements of the Department of Natural Resources.

13. A minimum distance of fifteen (15) feet shall be provided between all travel trailers and tents.

14. Year round occupancy of any camp site is prohibited.

15. Year round storage of Travel Trailers or campers is prohibited.

g. Recreational Facilities for public use.

## ARTICLE 10

### 110.1000 INTENSIVE AGRICULTURAL (A-2)

#### 110.1001 Purpose.

Section 10.01. The purpose of the “A-2” District is to provide for the accommodation of concentrated feedlot operations as well as other intensive agricultural use in the Township. The concept of the “A-2” District recognizes such agricultural uses while actual application of the district is an option by a farm operator and/or owner. Moreover, it is not mandatory to be in an “A-2” District to be able to maintain or continue an intensive agricultural use.

#### 110.1002 Permitted uses.

Section 10.02. None.

#### 110.1003 Special permit uses.

Section 10.03. Subject to the conditions and limitations found in Article 17.

- a. Any intensive farm or agricultural activities.
- b. The sale of farm or dairy produce which has been raised on the farm from which it is to be sold.
- c. Signs, when in accordance with the provisions of this Ordinance.
- d. Accessory uses or building, when in accordance with the provisions of this Ordinance.

#### 110.1004 Application for special permit use.

Section 10.04. In the case of an application for rezoning to the “A-2” Agriculture District, the applicant must provide the following information:

- a. A map depicting the location of the actual operation in relation to the bulk of the owner and/or operator’s property, as well as the surrounding land use within one-half (1/2) mile of the site.
- b. A statement describing the use of the site, hours of operation, etc.

#### 110.1005 Standards.

Section 10.05. The granting of an “A-2” Intensive Agriculture District permit shall be governed by the following standards:

- a. Rezoning to the “A-2” Intensive Agriculture District may not be granted if both of the following conditions exists:
  - (1) The subject is question is contiguous to or within five hundred (500) feet of land zoned for residential or commercial use along seventy five (75%) percent or more of its perimeter.
  - (2) The property in question is shown as a non-agricultural use on Land Use Plan of the community and its non-farm development is timely.
  
- b. If said operation entails the confined feeding and/or production of livestock that it meet at least one of the following conditions.
  - (1) 300 or more cattle,
  - (2) 600 or more swine, goats or sheep,
  - (3) 30,000 or more fowl,
  - (4) 4 or more cattle/acre,
  - (5) 20 or more swine/acre,
  - (6) 700 or more poultry/acre, or
  - (7) 10 or more sheep or goats/acre.
  
- c. That the subject site is used solely for said operation for a period of at least 180 days per year.
  
- d. That agricultural products, such as but not limited to grain, bedding plants, livestock, etc., that are not raised on the owner’s or operator’s property are prohibited from being transported to the subject site for commercial processing and/or shipping.

## **ARTICLE 11**

### **110.1100      AGRICULTURAL, INDUSTRY/BUSINESS (A-3)**

#### **110.1101      Purpose.**

Section 11.01. The purpose of the “A-3” Agricultural District is to provide for the accommodation and regulation of manufacturing, warehousing, storage and related commercial activities that are dependent upon or closely allied to the agricultural industry. To these ends, the “A-3” District is designed and intended to be applied in either agricultural or industrial areas.

#### **110.1102      Permitted uses.**

Section 11.02.

- a.      Contracts sorting, grading and packaging services for fruits and vegetables.
- b.      Canning of fruits, vegetables, preserves, jams and jellies, including speciality foods.
- c.      Production of natural and processed cheese.
- d.      Wet milling of corn.
- e.      Preparation of feeds for animals and fowl.
- f.      Production of flour and other grain mill products.
- g.      Fluid milk processing.
- h.      Production of frozen fruits, fruit juices, vegetables and other specialities
- i.      Meat packing.
- j.      Poultry and small game dressing and packing, provided that all operations be conducted within an enclosed building.
- k.      Livestock sales facilities.
- l.      Grain elevators and bulk storage of feed grains.
- m.      Commercial greenhouses.
- n.      Fertilizer production, sales, storage, mixing and blending.

- o. Sales or maintenance of farm implements and related equipment.
- p. Soil mixing for commercial sale.
- q. Any farming or agricultural use, excluding intensive farm practices.
- r. Drying and dehydrating fruits and vegetables.
- s. Production of sausages and other meat products providing that all operations be conducted within an enclosed building.
- t. Fruit and vegetable pickling.
- u. Production of creamery butter.
- v. Living quarters for watchman and caretaker.
- w. Veterinarian services.
- x. Signs when in accordance with the provisions of this Ordinance.
- y. Accessory uses or buildings when in accordance with the provisions of Article 14.

**110.1103 Special permit uses.**

Section 11.03. Subject to the conditions and limitations found in Article 17.

- a. Any similar or related agri-business use as described above as may be determined by the Planning Commission.
- b. Riding stables, kennels.
- c. Slaughtering of animals.
- d. Auto service body shop.
- e. Retail/wholesale dealership.

## ARTICLE 12

### 110.1200

### COMMERCIAL DISTRICT (C-1)

#### 110.1201 Purpose and intent.

Sec. 12.01. This district provides for retail, convenience goods, and services for residents and recreational users in the area.

#### 110.1202 Principal uses permitted.

Section 12.02. No principal use of land is permitted in this commercial district except the following uses after a site plan submitted and evaluated by the Planning Commission has been approved by the Township Board:

- a. Shops and stores offering convenience and other goods such as groceries, drugs, liquor, hardware, gifts, antiques, laundromat, dry cleaning, drug stores, florists, jewelry, shoes, books, news stands.
- b. Services including banks, offices, art and photo studios, motels, hotels, inns, funeral homes, clinics, veterinary hospitals when animals are housed within a building, drive-in food services.
- c. Entertainment uses including theaters, restaurants, taverns, bowling alleys, skating rinks, tennis courts, golf driving ranges, miniature golf, and baseball ranges.
- d. Recreational equipment sales when goods or equipment are entirely housed within an enclosed building or displayed outdoors.
- e. Electrical, plumbing and automotive repair shops provided that all materials, equipment and parts are stored within an enclosed structure.
- f. Public utility buildings and structures including water and sewer system component facilities.
- g. Lodges, clubs and fraternities.
- h. Repair of appliances, radios, and televisions.
- i. *Existing Single Family Dwellings, as of August 1, 1988.* In those situations where an existing single family dwelling has been destroyed by fire, or Act of God, an owner may replace the dwelling when the replacement unit is of better quality than the previous unit before it was destroyed. Also, if the dwelling unit is being willfully removed in order to build a replacement that is of better quality.

In both of these situations, all codes and conditions of this and other ordinances shall be met.

(Ord, No. 110-1200, 11/01/1993)

**110.1203 Special permit uses.**

Section 12.03. Subject to the conditions and limitations found in Article 17.

- a. Auto service body shops.
- b. Commercial repair shops.
- c. Storage garages.

**110.1204 Accessory uses permitted.**

Section 12.04. Those uses customarily accessory to those uses permitted in the commercial district are allowed subject to the provisions of Article 14.

**110.1205 Additional requirements.**

Section 12.05. Height, lot area, frontage width, yard area and floor area requirements and restrictions as set forth in Article 16 shall also be complied with.

## **ARTICLE 13**

### **110.1300 INDUSTRIAL DISTRICT (I-1)**

#### **110.1301 Purpose and intent.**

Section 13.01. The intent and purpose of the industrial district is to provide for the existing and future industrial and related activities of the Township and village area economy. Further intent is to guide such industrial development in such a manner that no significant adverse environmental effect results from the development.

#### **110.1302 Principal uses permitted.**

Section 13.02. No principal use of land is permitted in the industrial district except the following uses after a site plan submitted and evaluated by the Planning Commission has been approved by the Township Board:

- a. Agricultural products processing including field and specialty crops and farm animals processing.
- b. Steel and other metals processing and fabrication.
- c. Cloth and fabric processing and fabrication.
- d. Plastics processing and fabrication.
- e. Electrical and electronics manufacture and fabrication.
- f. Trucking and rail shipping terminals and facilities.
- g. Dry cleaning and laundry processing plants.
- h. Flour and grain mills.
- i. Bottling and canning plants.
- j. Contractor's equipment and storage yards.
- k. Lumber and wood products manufacturing and fabrication.

#### **110.1303 Specific use requirements.**

Section 13.03. The following requirements shall apply to all industrial development within the Township following the effective date of this Ordinance:

- a. Uses permitted in this district shall be conducted in completely enclosed buildings except that permitted outdoor storage yards shall be completely enclosed by a chain link fence or masonry wall not less than five (5) feet nor greater than eight (8) feet in height, with gates at points of entrance and exit.
- b. Noise emanating from a use permitted in this district shall not exceed the level of average street noise on abutting streets.
- c. Uses in this district shall be conducted so that they do not emit any gas which is harmful to the public health, safety or welfare or corrosive to structures except for those produced by internal combustion engines under designed operating conditions, produce no glare or heat humanly perceptible at or beyond the boundaries of the property, discharge into the air no dust or other particulate matter created by any industrial operation or emanating from any products or materials stored on the premises, produce no vibrations humanly perceptible at or beyond the boundaries of the property, produce no electromagnetic radiation or radioactive emission injurious to human beings, animals or vegetation or which exceed quantities established by the U. S. Bureau of Standards, do not engage in the production or storage of any materials designed as an explosive.

**110.1304 Additional requirements.**

Section 13.04. Height, lot area, frontage width, yard area and floor area requirements and restrictions as set forth in Article 16 shall also be complied with.

## ARTICLE 14

### 110.1400 ACCESSORY USE PROVISIONS

#### 110.1401 Accessory buildings.

Section 14.01. Accessory buildings, except as otherwise permitted in this Article, shall be subject to the following regulations:

- a. In a residential district there shall be two types of accessory buildings subject to the following specific regulations:
  - i. *Private garage.* There shall not be more than one (1) garage constructed on a lot and then, only where there is also a principal building located on that lot. Such a garage shall not be larger than nine hundred (900) square feet in the R-1 District, and if detached, shall not exceed sixteen (16) feet in height. No garage may be constructed in a front yard.
  - ii. *Utility buildings.* A building constructed for storage of personal property. There shall be no more than two (2) utility buildings on any lot.
- a. Where the accessory building is structurally attached to a main building, it shall be subject to, and must conform to, all regulations of this Ordinance applicable to the main building.
- b. Detached accessory buildings may be erected in any required yard, except a garage shall be erected in a side or rear yard only.
- c. If attached to the main structure, a garage may reach a height allowed for the main structure. If the garage is detached from the main structure, it may not exceed sixteen (16) feet in height, nor shall it be closer than ten (10) feet to the main structure.
- d. An accessory building ten (10) feet or less in height must be set back a minimum of five (5) feet from any adjacent lot line. An accessory building in excess of ten (10) feet in height shall be set back a minimum of ten (10) feet from any adjacent lot line, and any accessory building over twelve (12) feet in height shall be set back an additional foot, for each two (2) foot increase in height. In those instances where the rear lot line is shared with an alley right-of-way, the accessory building shall not be closer than three (3) feet to such a rear lot line. In no instance shall an accessory building be located within a dedicated easement right-of-way.
- f. No detached accessory building shall exceed one (1) story or sixteen (16) feet in height.

g. Accessory buildings and structures may be erected prior to the establishment of a principal building, following approval of the Zoning Administrator.

(1) In Residential Districts approval for accessory buildings prior to the establishment of a principal use shall be for one (1) year. Extensions may be issued by the Zoning Administrator if obtained prior to expiration of the one year limit.

(2) There shall be no time limit restrictions for accessory buildings prior to the establishment of a principal use in Agricultural Districts.

#### **110.1402 Accessory vehicle storage.**

Section 14.02. In any district which has residential use as a principal use, the parking of licensed or outdoor storage of passenger automobiles, one (1) commercial vehicle of less than one (1) ton carrying capacity, one (1) recreational camping vehicle (whether self-motorized or trailer type), and one (1) trailer carrying other recreational equipment shall be permitted. All other parking and storage of vehicles shall be prohibited as an accessory use. No mobile homes may be stored. No camping trailer may be occupied except as specifically allowed under this Ordinance. Any vehicles described in this section are further subject to all provisions of any other Township ordinance adopted under the police power of this Township, further regulating such vehicles. This section shall be a supplement to those.

## ARTICLE 15

### 110.1500 NONCONFORMING USES, LOTS AND STRUCTURES

#### 110.1501 Intent.

Sec. 15.01. It is the intent of this Ordinance to permit *legal* nonconforming lots, structures or uses to continue until they are brought into conformity, removed, extinguished, or forfeited, but not to encourage their survival.

#### 110.1502 Nonconforming lots.

Sec. 15.02. Any nonconforming (substandard) lot of less than fifteen thousand (15,000) square feet, shall meet the minimum regulations of the dimensional requirements of this Code, except as they may be allowed to use such substandard nonconforming lots consistent with the provisions of Section 3.06.

#### 110.1503 Nonconforming uses of land.

Section 15.03. Where, on the effective date of adoption or amendment of this Ordinance, lawful use of land exists that is made unlawful under the terms of this Ordinance as enacted or amended, such use may be continued, so long as it remains otherwise lawful, subject to the following provisions:

- a. No such nonconforming use shall be enlarged or increased, nor extended to occupy a greater area of land than was occupied at the effective date of adoption or amendment of this Ordinance.
- b. No such nonconforming use shall be moved in whole or in part to any other portion of the lot or parcel occupied by such use at the effective date of adoption or amendment of this Ordinance.
- c. If such nonconforming use of land ceases for any reason for a period of more than twelve (12) months, any subsequent use of such land shall conform to the regulations specified by this Ordinance for the District in which such land is located.
- d. Notwithstanding the other provisions contained in this Article, when a residence is classified as nonconforming, alterations, repairs and additions, including accessory buildings, may be erected, provided the value of all such

alterations, repairs and additions, including accessory buildings, as determined by the Zoning Administrator, does not exceed fifty (50 %) percent of the appraised value of the nonconforming residence, cumulative from the date of nonconformance to the date of request.

- e. Notwithstanding the foregoing, nothing in this Article shall be construed to prohibit the alteration, improvement or addition to a previously nonconforming structure if that nonconforming structure is first brought into conformity with the provisions of this Ordinance.

**110.1504 Nonconforming structures.**

Sec. 15.04. Where a lawful structure exists at the effective date of adoption or amendment of this Ordinance that could not be built under the terms of this Ordinance by reason of restrictions on area, lot coverage, height, yards, parking or other characteristics of the structure or its location on the lot, such structure may be continued so long as it remains otherwise lawful, subject to the following provisions:

- a. No such structure may be enlarged or altered in a way which increases its nonconformity.
- b. Should such structure be destroyed by any means to an extent of more than fifty (50%) percent of its replacement costs, it may not be reconstructed for its original nonconforming use.
- c. Should such structure be moved for any reason for any distance whatever, it shall thereafter conform to the regulations for the district in which it is located after it is moved.

**110.1505 Nonconforming uses of structures and land.**

Sec. 15.05. If a lawful use of a structure, or of structure and land in combination, exists at the effective date of adoption or amendment of this Ordinance, that would not be permitted in the district under the terms of this Ordinance, the use may be continued so long as it remains otherwise lawful, subject to the following provisions:

- a. No existing structure devoted to a use not permitted by this Ordinance in the district in which it is located shall be enlarged, extended, constructed, reconstructed, moved or structurally altered, except

in changing the use of the structure to a use permitted in the district in which it is located.

- b. When a nonconforming use of a structure, or structures and land in combination, is discontinued or ceases to exist for twelve (12) consecutive months, the structure or structure and land in combination, shall not thereafter be used except in conformance with the regulations of the district in which it is located.
- c. Where nonconforming use status applies to a structure and land in combination, removal, or destruction of the structure shall eliminate the nonconforming status of the land.

**110.1506 Repair and maintenance of nonconforming uses.**

Sec. 15.06. Such repairs and maintenance work as required to keep it in sound condition may be made to a nonconforming building or structure, provided that no structural alterations shall be made in such building or structure which, during its life subsequent to the date of its becoming nonconforming, exceed fifty (50%) percent of its assessed value for tax purposes at such date unless changed to a conforming structure.

**110.1601 Footnotes to schedule of regulations.**

Sec. 16.01

- a. In the case of corner lots, the designated side yards abutting a street shall be equal in depth to the front yard setback requirements for the district, except where the adjoining lot on the side street has an existing dwelling, the front yard setback need not be greater than established by the existing dwelling, but in no case shall the setback be reduced to less than 20 feet.

Minimum yard width and area requirements may deviate not more than ten percent for approved subdivisions, provided the listed minimum lot sizes are met on an average, and further provided the allowed deviation will not result in the creation of an attendant increase in the number of lots.

- b. In the C-1 District, no single business shall have a retail floor space in excess of 6,000 square feet.
- c. For residential lots with lake frontage, the lake side shall be considered the front yard.
- d. Mobile home trailer parks shall have a minimum of 20 acres.
- b. Farms on those parcels of land separately owned outside the boundaries of a subdivision, shall have not less than five acres for raising of farm animals, subject to the conditions found in Article 7.

Private stables as an accessory use for not more than one horse on a lot not less than two acres in area and provided further that for each additional horse stabled thereon, on additional acre of land shall be provided. Horses shall not be pastured, fenced, or penned within 200 feet of an adjacent dwelling and shall be subject to the conditions found in Article 7.

- c. At level of two head of livestock, add 1.5 acres for each head over two, up to twelve total.
- d. 30,000 square feet for two family dwelling.
- e. 1,000 feet setback from any existing Church, business, school, or recreation area.

**110.1602 Standards and regulations for Residential-Estate (R-3).**

Sec. 16.02. Purpose. The purpose and intent of this Ordinance is to amend Article 16 to include the standards and regulations applicable in the Residential-Estate District (R-3) to read as follows:

**RESIDENTIAL ESTATE (R-3)**

Height, lot area, frontage width, yard area, and floor area requirements and restrictions shall further be complied with as set forth in Article 16.

Minimum Lot Size – 50,000 square feet

Minimum Lot Width – 200 feet

Minimum Lot Depth – 250 feet

Maximum Height of Buildings – 2 stories (40 feet)

Minimum Floor Area – 1,000 square feet

Minimum Yard Setback – 100 feet from the established center of a dedicated right-of-way, 20 feet least 1 side, 40 feet total, 20 feet from back line.

Minimum Dwelling Unit Width – 24 feet on an unbroken building line, excluding garages and accessory structures.

No animals except common household pets may be kept on the premises, and no more than 4 such animals in any combination.

(Ord. No. 110.1600A eff. Feb 5, 1992)

## ARTICLE 17

### 110.1700 SPECIAL LAND USE PERMITS

#### 110.1701 Purpose.

Sec. 17.01. Land and structure uses possessing these particularly unique characteristics are designated as Special Uses and may be authorized by the issuance of Special Use Permits with such conditions and safeguards attached as may be deemed necessary for the protection of the public welfare.

The following standards and procedures are designed not only for all special uses referred to in various districts, but are to be applied also to PURD Districts.

#### 110.1702 Procedures for making application.

Sec. 17.02.

- a. *APPLICANT.* Any person owning, or with the consent of the owner, or a person having an interest in the subject property, may file an application for one or more Special Use Permits provided for this Ordinance in the zoning district in which the land is situated.
- b. *APPLICATION.* Application shall be submitted through the Township Clerk to the Planning Commission on a special form provided for that purpose; each application shall be accompanied by the payment of a fee in accordance with the duly adopted "Schedule of Fees", to cover the cost of processing the application. The "Schedule of Fees" shall be approved by the Township Board and attached to all public copies of this Ordinance, including those which shall be kept by the Casnovia Township and Muskegon County Clerks. No part of any fee shall be refundable.

#### 110.1703 Data required in application.

Sec. 17.03. Every application shall be accompanied by a site plan or development plan, drawn to a readable scale showing:

- a. Property dimensions and legal description,
- b. Size, shape and location of existing and proposed buildings,
- c. Topographical information,
- d. Hydrographical information (optional),

- e. Soil Types (optional),
- f. Photographs (optional),
- g. Streets and highways; private easements,
- h. Parking, parking spaces and driveways,
- i. Loading zones,
- j. Entrances to public streets,
- k. Anticipated amount of traffic to be generated and circulation of traffic,
- l. Building(s) location, dimensions and proposed uses,
- m. Description of building design, including proposed construction materials,
- n. Drainage facilities, watercourses, water bodies, including surface drainage,
- o. Location and description of method to dispose of sanitary wastes,
- p. All proposed landscaping and significant existing vegetation and existing vegetation to be removed.
- q. Types of machinery, power usage, electrical equipment, and watts, discarded materials and emissions produced from the activity of the use,
- r. Signs proposed,
- s. Any additional information such as legal survey, engineering or architectural drawings, or other information deemed to be necessary to carry out their duties.

**110.1704 Additional information and waiver.**

Sec. 17.04. The Planning Commission may require maps, soil, topographical and hydrographic studies, engineering or architectural drawings and plans, photographs, legal surveys and in case of larger projects, environmental impact statements, but the Planning Commission is not limited hereby, and may require such other documents and information as may be appropriate or needed for its review.

The Planning Commission may, upon request with a showing that information is not needed to make a determination, waive any of the above points of information otherwise required.

**110.1705. Procedure for review and findings – public hearing.**

Sec. 17.05. The Planning Commission shall review the application and site plan as soon as practicable following filing and shall set a date for public hearing within forty five (45) days there after. The Planning Commission shall cause to be published one (1) notice of public hearing not less than five (5) days nor more than fifteen (15) days before the date the application will be considered and shall notify by regular mail the parties of interest and all property owners within three hundred (300) feet of the subject property and Township Board Members. The notice shall contain the time, date, place and reason for the hearing. A brief description of the type of use being applied for shall be included. The Planning Commission shall hold its public hearing, compile information and input received and shall make its recommendation to the Township Board within thirty (30) days.

**110.1706 General standards for making determinations.**

Sec. 17.06. The Planning Commission and the Township Board shall, upon separate occasions, review the particular facts and circumstances of each proposal in terms of all of the following standards and each shall find adequate evidence showing that the proposed use:

- a. Will be harmonious with and in accordance with the general objectives or with any specific objectives of the zoning ordinance;
- b. Will be designed, constructed, operated and maintained so as to be harmonious and appropriate in appearance with existing or intended character of the general vicinity and that such a use will not change the essential character of the same area;
- c. Will not be hazardous or disturbing to existing or future neighboring uses and will not cause disturbing emission of electrical discharges, dust, lights, vibrations, or noise;
- d. Will be served adequately by existing essential public facilities and services; such as highways, streets, police and fire protection, drainage structures, refuse disposal or schools; or that the persons or agencies responsible for the

establishment of the proposed use shall be able to provide adequately any such service;

- e. Will not create additional requirements at public cost for public facilities and services, and will not be detrimental to the economic welfare of the Township;
- f. Will not involve uses, activities, processes, materials and equipment and conditions of operation that will be detrimental to any persons, property or the general welfare by reason of excessive production of traffic, noise, smoke, fumes, glare, odors, or require outdoor storage of raw materials or discarded materials produced in the use processes;
- g. Will be consistent with the intent and purposes of this Ordinance;
- h. Whether a hazard to life, limb, or property caused by fire, flood, erosion or panic may be created by reason or as a result of the use, or by the structures to be used therefor, or by the inaccessibility of the property or structures, thereon for the convenience of entry and operation of fire and other emergency apparatus or by the undue concentration or assemblage of persons upon such plot;
- i. Whether the use, or the structures to be used therefor will cause an overcrowding of land or undue concentration of population;
- j. Whether the plot area is sufficient, appropriate and adequate for the use and the reasonable anticipated operation and expansion thereof.

**110.1707 Conditions and safeguards; termination.**

Sec. 17.07. The following conditions may further apply to the grant of a Special Use Permit:

- a. Prior to the granting of a Special Use Permit, the Planning Commission may recommend any additional conditions or limitations upon the establishment, location, construction, maintenance or operation of the use authorized by the Special Use Permit as in its judgment may be necessary for the protection of the public interest.
- b. Conditions and requirements stated as part of Special Use Permit authorization shall be a continuing obligation of

Special Use Permit holders. The Zoning Administrator shall make periodic investigations of developments authorized by Special Use Permits to determine compliance with all requirements.

- c. Special Use Permits may be issued for time periods as determined by the Planning Commission. Special Use Permits may be renewed in the same manner as originally applied for.
- d. Continuance or revocation of a Special Use Permit by the Board shall occur upon a determination by the Zoning Administrator that:
  - i. The time limit granted has expired.
  - ii. Violations of conditions pertaining to the granting of a permit continue to exist more than thirty (30) days after an order to correct has been issued.
  - iii. If a Special Use Permit has been granted, but the use allowed is not commenced within six (6) months, it shall terminate automatically and a new application must be filed. A renewal of the permit may be requested before the end of the six (6) months.
  - iv. Except for nonuse, revocation of a granted permit may occur only after a hearing before the Board with good cause shown.

**110.1708 Recommendation to Township Board.**

Sec. 17.08. Upon conclusion of the public hearing or at the next meeting thereafter, the Planning Commission shall recommend approval or denial of an application for a Special Use Permit to the Township Board. Recommendations shall include an accurate description of the proposed special use, a description of the property upon which the Special Use is sought to be located, recommendations and proposed conditions of the Planning Commission, along with a summary of the comments at the meeting of the Planning Commission considering the application.

**110.1709 Township Board; issuance/denial of Special Use Permit.**

Sec. 17.09. The Township Board may affirm, modify or deny the application for Special Use Permit with all conditions; and, if approved, instruct the Zoning Administrator to issue the Special Use Permit with the conditions. If the conditions are required prior to or with the permit, they shall be typed on paper and signed by the Township Clerk, as authorized by the Board and the applicant, and recorded with the County Register of Deeds.

**110.1710 Decision.**

Sec. 17.10. Upon making a decision, the Township Board shall incorporate, in a statement of conclusion, the factual basis and reasons for the grant or denial of the application in written findings of fact.

**110.1711 Modification of approved Special Use Permit Plan.**

Sec. 17.11. Once approval of the Special Use Permit Plan has been granted by the Township Board, changes to the approved plan shall require a resubmission to the Board of the modifications which shall not require the other procedural steps.

**110.1712 Appeals and questions of interpretation of ordinance.**

Sec. 17.12. Any interested person considering himself aggrieved by the decision of the Township in the granting or denial of the Special Use Permit shall have the right to appeal the said decision to the Circuit Court within thirty (30) days after a written decision is submitted to the Clerk. An "interest person" shall be the owner-developer, a person living within three hundred (300) feet of the site, or a person who can show a significant interest, whether economic or not. There will be no appeal to the Zoning Board of Appeals.

## ARTICLE 18

### 110.1800 SPECIAL LAND USE STANDARDS AND REGULATIONS

#### 110.1801 Scope, purpose and intent.

Sec. 18.01. This Article identifies certain land uses which can cause complaints from adjacent landowners, or are designed to protect the long-range development interests of the Township by imposing these conditions on specific land uses, some of which can be found in several zoning districts.

#### 110.1802 Animal hospitals/Clinics

**Sec. 18.02.** The following conditions shall apply:

- a. No animal hospital or clinic may be located adjacent to a residential lot on any side.
- b. No animal may be left outside between 9:00 P.M. and 7:00 A.M.
- c. All pens must be a minimum of one hundred fifty (150) feet from any adjacent property line.
- d. Waste material may not be disposed of on the premises unless the parcel is five (5) acres minimum, and such method of handling and disposal shall not cause a threat or polluting the underground water table, or create a nuisance caused by odor, runoff or like acts.

#### 110.1803 Auto service body shops and commercial garages.

Sec. 18.03

- a. *Intent.* The following uses may be permitted in conjunction with automotive service body shops and commercial garages:
  - i. Parking and storage of inoperative vehicles, providing that such parking or storage shall be within an enclosed building or shall be screened by an opaque fence not less than six (6) feet in height and in no case shall the material stored exceed the height of the screen or be visible from any roadway.
  - ii. Major automobile repair.
- b. The following additional standards shall apply to site development:

- i. There shall be three hundred (300) square feet of site area for each space intended for storage of inoperable vehicles.
  - ii. The minimum site width shall be two hundred (200) feet with a minimum site area of twenty thousand (20,000) square feet.
  - iii. Commercial garages shall have an additional one thousand (1,000) square feet of site area for each additional service bay over two (2). There shall also be three hundred (300) square feet of additional site area for each space intended for storage of inoperable vehicles.
  - iv. All equipment including automobile washing, dismantling, repairing equipment and body or mechanical repair shall be entirely enclosed within a building. Any portion of a building containing an auto body shop or washing areas shall consist of a solid exterior masonry wall or equivalent, approved by the Administrator, with no openings other than those required for access. There shall be no outdoor storage of merchandise such as tires, lubricants, and other accessory equipment except that the outdoor trash storage may be provided in a properly screened container.
- c. No automobile which is left for repair may remain on the premises longer than forty five (45) days. Any inoperable automobile which is involved in a collision, and may not be repaired at that location, because of the nature or extent of repairs, may not be left on the premises for a period exceeding fifteen (15) days.
- d. The automobile service body shop or commercial garage shall provide one (1) parking space for each person employed during any given period of the day. Each required parking space shall be no less than two hundred (200) square feet in area.

**110.1804 Automobile service stations.**

Sec. 18.04. It is the intent of this section to provide standards for automobile service stations.

- a. The following uses may be permitted in conjunction with automobile service stations:
  - i. Retail sales of gasoline, oil and similar products.
  - ii. Automobile washing.
  - iii. Automobile maintenance, including minor mechanical repairs.

b. The above uses shall comply with the following site development standards:

- i. Gasoline service stations shall have five hundred (500) square feet of additional site area for each additional pump over four (4).
- ii. All equipment including hydraulic hoist, pits, and oil lubrication, greasing, and automobile washing, and repairing equipment shall be entirely enclosed within a building.

Any such portion of a building containing washing areas shall consist of a solid exterior masonry wall or equivalent, approved by the Administrator, with no openings other than those required for access. There shall be no outdoor storage of merchandise such as used tires, lubricants, and other accessory equipment except that outdoor trash storage may be provided in a property screened container.

- iii. All activities, except those required to be performed at the fuel pump, shall be carried on inside a building. All vehicles upon which work is performed shall be located entirely within a building.
- iv. The automobile service station shall provide one (1) parking space for each employed at the station during any given period of the day. Each required parking space shall be no less than two hundred (200) square feet in area. No outdoor storage or parking of vehicles other than those used by employees while on duty, will be permitted, except vehicles waiting to be serviced.

**110.1805 Commercial TV, radio tower, public utility, microwave towers, wind power generation towers.**

Sec. 18.05.

a. Antennae and towers or antenna shall not be erected in any zoning district in violation of the following restrictions:

- i. No part of any tower or antenna shall be constructed, located or maintained at any time, permanently or temporarily, in or upon any required setback area for

the district in which the antenna or tower is to be located.

- ii. The required setback for antenna and tower not rigidly attached to a building and whose base is on the ground, may reduce this required setback by the amount equal to the distance from the point of attachment to the ground.
  - iii. No tower shall be in excess of height equal to the distance from the base of the antenna and tower to the nearest overhead electrical power line which serves more than one (1) dwelling or place of business, less five (5) feet and located no closer than fifteen (15) feet of any utility line.
  - iv. Metal towers shall be constructed of, or be treated with, corrosive-resistant material. Wood poles shall be impregnated with rot resistant substances.
- b. No part of any antenna or tower nor any lines, cable, equipment or wires or braces in connection with either shall at any time extend across or over any part the right-of-way, public street, highway, sidewalk or property line.
  - c. Towers with antennae shall be designed to withstand a uniform wind loading as prescribed in the Uniform Code, as now in force or as hereafter adopted.
  - d. Antennae and metal towers shall be grounded for protection against a direct strike by lightning and shall comply as to electrical wiring and connections with all applicable local statutes, regulations and standards.
  - e. All signal and remote control conductors of low energy extending substantially horizontally above the ground between a tower or antenna and a structure, or between towers shall be at least eight (8) feet above the ground at all points, unless buried underground.
  - f. Every tower affixed to the ground shall be protected to discourage climbing of the tower by unauthorized persons.

**110.1806 Farms and animals.**

Sec. 18.06. The following conditions shall apply to farms containing animals:

- a. No barn may be located closer than one hundred (100) feet from the road right-of-way, or two hundred (200) feet from the nearest adjacent lot line.
- b. Farm animals shall be fenced or penned with materials sufficient to contain the animals. Any animals running at large shall be prima facie evidence that the enclosure was not sufficient.
- c. No farm animals may be pastured, fenced or penned within one hundred (100) feet of any adjacent dwelling, or any point closer than seventy-five (75) feet of a road right-of-way unless in a pasture. A definable front, side or back yard, shall not be considered a pasture.

**110.1807 Horseback riding stables.**

Sec. 18.07. It is the intent of this section to provide standards for riding stables.

- a. Roadways shall be adequate to service guests, but no more extensive than is necessary and shall be maintained in a condition adequate for access and on-site movement of emergency vehicles.
- b. Water supply and wastewater disposal and treatment systems and facilities shall be approved by the County Health Department.
- c. The location and improvement of the trail system must be safe and not cause environmental damage.
- d. The proposed trail system will not unreasonably affect adjoining property.
- e. The proposed plan for operating the trail system, including hours of the day for use, safety, emergency facilities, regulation and control of trails and off-trail areas, trail relationship to available toilet and waste disposal facilities, is found by the Planning Commission to be adequate for environmental protection, health, safety or trail users and the general community.
- f. Assembly and rest areas shall include adequate parking areas, toilet facilities and solid waste

containers and the Planning Commission may impose other limitations and requirements found necessary to fulfill the purposes of this Ordinance.

**110.1808 Private parks/winter sports area.**

Sec. 18.08. The following conditions shall apply to private parks and winter sports areas:

- a. All improvements, buildings and structures and uses shall be found by the Planning Commission not to pose any health or safety hazard nor the threat of significant damage to the environment.
- b. When a trail system is proposed, a plan shall show the location of the trail system and include hours of the day or night use, safety and emergency facilities, regulation and control of trails and off-trail areas, trail relationship to available toilet and waste disposal facilities.
- c. Assembly areas shall include adequate ingress and egress roads, parking areas, toilet facilities and solid waste containers.

**110.1809 Shooting ranges, gun and skeet clubs.**

Sec. 18.09. The following conditions shall apply to the above land use:

- a. Minimum lot area, forty (40) acres.
- b. Minimum front, side and rear yards of two hundred fifty (250) feet.
- c. Hours of operation – 9:00 A.M. till 9:00 P.M.
- d. Separation from residential dwelling and district-the shooting range shall not be closer than one quarter (1/4) mile from all dwellings, residentially zoned districts and farm animals.
- e. Rifle and pistol ranges shall have adequate back stops that meet the approval of the Planning Commission.

**110.1810 Signs and sign boards.**

Sec. 18.10. No person, firm or corporation shall erect or cause to be erected on or along any highway within Casnovia Township any sign or billboard, except a permit may be granted for a sign or advertising device not exceeding 16 square feet in size, advertising the business conducted upon the property abutting upon the highway at the place where the advertisement is situated. The location of such sign shall be approved by the Building Inspector, and provided further, that a permit for the erection and maintenance of the same shall first be issued an approval of the Board of Appeals. A permit fee, as established by resolution of the Township Board, shall be paid when the application is submitted. (Ord. No. 110-1800, 6-7-93)

**110.1811 Kennels, conditions regarding.**

Sec. 18.11. The following conditions shall apply to kennels as defined in S.2.25:

- (a) The minimum lot size for a kennel shall be five acres for operations having a maximum capacity of six animals. For capacities beyond six animals the acreage shall increase one-half acre for each animal added to the kennel's capacity. Such capacity shall be determined upon the number of animals in residence at any one time, and at no time may the number of animals exceed the stated kennel capacity.
- (b) No structure, runway, or pen shall be located within 150 feet from the front lot line, nor within 100 feet from the rear lot line, nor within 100 feet of the side lot line.
- (c) In addition to subparagraph (b), no structure, runway, or pen shall be located within 300 feet of any residence (other than the principle residence on the lot with the kennel).
- (d) The kennel operation shall be established and maintained to eliminate objectionable odors and conditions.
- (e) All animals on the premises shall be housed in a completely enclosed building between the hours of 10:00 p.m. and 8:00 a.m.
- (f) Adequate buffering measures shall be provided to reduce irritants to the sensory perceptions. Pens and runways shall be screened from view from the road and adjoining properties, either by buildings, a greenbelt of plantings, or a "noise and view" fence. Neither the plantings nor the fence shall be within three feet of any runway or pen. The greenbelt shall consist of vegetation that will maintain its density and screening effect throughout the calendar year

and shall be maintained in a neat and attractive manner commensurate with adjoining area.

Such “noise and view” fence shall consist of a fence constructed of masonry with sound baffles, a wood louver, or other similar type. The fence shall be no less than five feet and no more than eight feet high.

- (g) All yard space used for pen areas or runways shall be enclosed with a woven wire or other approved fencing material not less than five feet in height unless a lower height would effectively contain the animals. Such fence shall be maintained in good condition at all times. Barbed-wire fencing will not be allowed.
- (h) The owners of the kennel shall secure or renew as required, the permits issued by the Muskegon County Health/Animal Control Department as a condition to operate the kennel.  
(Ord. No. 110.1811 eff. Feb. 5 1992)

## ARTICLE 19

### 110.1900 SITE PLAN REVIEW STANDARDS

#### 110.1901 Scope, purpose and intent.

Sec. 19.01. Prior to being allowed to obtain a building permit, applicants shall be required to submit a site plan.

This section and article shall not apply to building permits for single family residential buildings.  
(Ord. No. 110-1900, § 2, 8-18-91; Ord. No. 110.1900A, 1-3-94)

#### 110.1902 Site plan review procedures.

Sec. 19.02.

- a. *Notice requirement.* All owners per tax roll records on date of application shall be entitled to notice that a described adjoining parcel of land will be subject to site plan review on or before a time, date and place certain by the Planning Commission, and their review of the proposed plan and remarks are invited in writing or in person on date of review.
- b. *Application and review.* Prior to making application for a building permit, a site plan of the proposed development shall be submitted to the Planning Commission by the developer. Such site plan shall include the entire area proposed for development. The Planning Commission shall have the authority to require adjustments in the site plan as a condition for approval if such adjustments are deemed necessary by the Commission to ensure that the proposed development meets all standards contained herein, and shall not excessively disturb the natural shore environment or the general residential character of the area.

Except as otherwise waived by the Planning Commission said site plan shall show and include the following, either existing or proposed:

- i. Site plan drawn to readable scale.
- ii. Property dimensions.
- iii. Size, shape and location of existing and proposed buildings.
- iv. Existing vegetation.
- v. Topographical information.
- vi. Hydrographical information.
- vii. Soil types.
- viii. Photographs (optional).
- ix. Streets and highways.
- x. Parking areas.
- xi. Loading zones.
- xii. Entrances to public streets.
- xiii. Anticipated amount of traffic to be generated and circulation of traffic.
- xiv. Building(s) location, dimensions and proposed uses.
- xv. Description of building design, including proposed construction materials.
- xvi. Drainage facilities.
- xvii. Location and description of method to dispose of sanitary wastes.
- xviii. All landscaping.
- xix. Sidewalks.
- xx. Anticipated market to be served by the proposed development, demonstrating that all proposed uses serve the ordinary needs of the surrounding residential area.

- xxi. Signs proposed.
- xxii. Any additional information such as a legal survey, engineering or architectural drawings, or other information deemed by them to be necessary to carry out their duties.
- xxiii. Current zoning on all adjacent land.

**110.1903**

**Standards for site plan approval.**

Sec. 19.03.

- a. All elements of the site plan shall be harmoniously and efficiently organized in relation to topography, the size and type of lot, the character for adjoining property and the type and size of buildings. The site will be so developed as not to impede the normal and orderly development or improvement of surrounding property for uses permitted in this Ordinance.
- b. The landscape shall be preserved in its natural state, insofar as practicable, by minimizing tree and soil removal, and by topographic modifications which result in maximum harmony with adjacent areas.
- c. Special attention shall be given to proper site surface drainage so that removal of storm waters will not adversely affect neighboring properties.
- d. All buildings or groups of buildings shall be so arranged as to permit emergency vehicle access by some practical means to all sides.
- e. Every structure of dwelling unit shall have access to a public street, walkway or other area dedicated to common use.
- f. There shall be provided a pedestrian circulation system which is insulated as completely as reasonably possible from the vehicular circulation system.

- g. All loading and unloading areas and outside storage areas, including areas for the storage of trash, which face or are visible from residential districts or public throughfares shall be screened, by vertical screen consisting of structural solid fence, earth berm, evergreen hedge, plant materials or equivalent materials no less than six (6) feet in height.
- h. Exterior lighting shall be so arranged that it is deflected away from adjacent properties and so that it does not impede the vision of traffic along adjacent streets. Flashing or intermittent lights shall not be permitted.

**110.1904**

**Site plan, water and drainage standards**

Sec. 19.04.

- a. *Relevant factors.* In examining any site plan, the Planning Commission may review those factors involving water availability, quality, discharge generated, discharge contents, land drainage, drain blockage. In their review, they may consider the following relevant factors:
  - i. The proposed water supply and sanitation systems and the ability of these systems to prevent disease, contamination and unsanitary conditions.
  - ii. The susceptibility of the proposed facility and its contents to high water damage on the individual owner.
  - iii. The availability of alternative locations not subject to high water hazards for the proposed use.
  - iv. The compatibility of the proposed use with existing development and development anticipated in the foreseeable future.
  - v. The relationship of the proposed use to land use and drainage plans and programs for the area.
  - vi. The safety of access to the property in times of high water for ordinary and emergency vehicles.
  - vii. Such other factors which are relevant to the purposes of this Ordinance.

b. *Site and performance and conditions.* Upon consideration of the factors listed above and intent of this section, the Planning Commission may recommend conditions prior to site plan approval as it deems necessary to further the purposes of this sections. Such conditions may include:

- i. Modification of waste disposal and water supply facilities.
- ii. Footings at least one (1) foot above the known high water level.
- iii. Connection to any drainage way.
- iv. Grading and sloping in a manner that protects all adjacent property owners.
- v. Construction and/or reinforcement of walls to resist water pressures due to unforeseen high water levels.
- vi. Use of paints, membranes or mortars to reduce seepage water through walls.
- vii. Installation of pumps and/or sumps to lower water in structures, linked to facilities which can transmit the water away from the structure.
- viii. Installation of valves or controls on sanitary and storm drains which will permit the drains to be closed to prevent back-up of sewage or storm waters.
- ix. Location of all electrical equipment, circuits and installed electrical appliances in a manner which will assure they are not subject to high water conditions.
- x. The natural existing characteristics of the land, streams, lakes, trees and vegetation shall be utilized to the greatest extent possible in the development of the site.
- xi. Other special information and other considerations relative to the existing site or the proposed site plan may be required if the Planning Commission deems them necessary to the protection of the public health, safety and general welfare.

Sec. 19.05.

- i. When the Planning Commission has received the application and documentation required, it shall make its findings on the plan, in writing, and set forth conditions for the approval of the plan.
- ii. The developer/owner shall incorporate the recommendations of the Planning Commission into a final plan, if necessary, and submit the same to the Commission for final approval.
- iii. The Planning Commission may, for good cause shown, waive any standard required for the site plan approval, if the spirit of the Ordinance will be preserved.
- iv. The conditions and plan, when approved by resolution adopted, shall be transmitted to the Building Inspection Department. No building permit may be authorized without such approval of the plan.
- v. The plan and conditions approved shall be followed continuously by the owner/developer, its successors or assigns. Cessation or deviation from the conditions and plan shall invalidate the approved land use and any permits or licenses issued by the City in reliance thereon and construe a violation of this Ordinance.
- vi. The Planning Commission may request adequate security for the performance of any conditions in the form of cash, bank cashier's check, certified check, construction bond, in such amount they feel reasonable.
- vii. Site plan approval shall be automatically terminated in one (1) year from the date of approval if no building permit has been granted, or if granted, no construction on the principle structure has commenced, excluding site preparation, unless the applicant obtains an extension for good cause shown, or the site plan was part of a Special Use Permit granted, in which case, the term shall be co-terminus with the Special Use Permit.

- viii. Where necessary, the Planning Commission may insist that the conditions for approval be signed by the applicant and recorded with the County Register of Deeds.

## ARTICLE 20

### 110.2000 ADMINISTRATION

#### 110.2001 Zoning Administrator; designation.

Sec. 20.01. The Township Board shall appoint one, or more, Zoning Administrator(s) whose duty it shall be to administer and enforce the provisions of this Ordinance.

#### 110.2002 Zoning Administrator(s); duties.

Sec. 20.02. In administering and enforcing this Ordinance, the Township Zoning Administrator shall perform the following duties:

- a. Provide necessary forms and applications;
- b. Determine and verify zoning compliance upon the demonstration that the applicant's plan are found to conform with the provisions of this Ordinance;
- c. The Zoning Administrator shall not vary, change or grant exceptions to any terms of this Ordinance, or to any person making application under the requirements of this Ordinance;
- d. Issue any authorized permits;
- e. Identify and record information relative to nonconformities;
- f. Provide assistance in zoning changes and amendments to the Ordinance text or map;
- g. Maintain files of applications, permits and other relevant documents and said records are open for public inspection.

#### 110.2003 Zoning administrator(s); powers.

Sec. 20.03. The Zoning Administrator(s) shall have all powers and authority conferred by laws, statutes and ordinances to enforce the provisions of this Ordinance.

#### 110.2004 Board of appeals; members; appointment.

Sec. 20.04. There is herewith created a Board of Appeals consisting of three (3) members. Members shall be appointed by the Township Board, provided that no elected officer of the Township shall serve as Chairman of

the Board of Appeals and that one (1) member of such Board of Appeals shall be a member of the Planning Commission. One (1) member may be a member of the Township Board. And one (1) member shall be chosen from the public at large and shall not be an elected official or member of the Planning Commission.

**110.2005 Terms**

Sec. 20.05. Of the members appointed to the first Board, one (1) shall serve a term of one (1) year, one (1) shall serve a term of two (2) years, and one (1) shall serve a term of three (3) years. Thereafter, all members shall be appointed for a term of three (3) years. Provided that each member shall serve until his successor is duly appointed.

**110.2006 Board of Appeals; compensation.**

Sec. 20.06. Members of the Board of Appeals may be paid compensation in an amount determined by the Township Board and may be paid their necessary expenses in the performance of official duties.

**110.2007 Board of Appeals; officers.**

Sec. 20.07. A chairman and vice-chairman shall be elected from among the members, and a secretary shall be appointed who need not be a member of the Board of Appeals.

**110.2008 Board of Appeals; powers.**

Sec. 20.08. The Board of Appeals shall have and exercise the following powers:

- a. To adopt rules of procedure governing the transaction of its business.
- b. To hear and decide appeals from and review any order, requirement, decision or determination made by any administrative official charged with enforcing the provisions of this Ordinance.
- c. To order the issuance of permits for buildings and uses.
- d. To ascertain in which district any unspecified use should be located, by determining which district has the most similar comparable uses.

**110.2009 Variances.**

Sec. 20.09. The Board of Appeals shall further have the power to order the issuance of variances.

- a. *Dimensional variance.* A dimensional variance from any standard established in this Ordinance may be granted in the discretion of the Board to allow a modification from such standard establishing area, yard, height, floor space, frontage, setback, or similar restriction, but only after substantive evidence establishes that there are “practical difficulties”, or “unnecessary hardships” in carrying out the strict letter of this Ordinance. They shall be granted only when they are in harmony with the general purposes and intent of this Ordinance and only after consideration of the following factors:
  - (a) how substantial the variance is in relating to the zoning requirements;
  - (b) the effect, if the variance is allowed, of the increased population density thus generated on available governmental facilities;
  - (c) whether a substantial change will be affected in the character of the neighborhood or a substantial detriment created for adjoining properties;
  - (d) whether the difficulty can be eliminated by some feasible method, other than a variance;
  - (e) whether, in view of the manner in which the difficulty arose, and considering all of the above factors, the interest of justice will be served by allowing the variance;
  - (f) the plight of the landowner is due to the circumstances unique to his property not created by the landowner.
  
- b. *Hearings and appeals.*
  - i. Appeals may be taken by any person affected, including the Township Board, or by an officer, department, board or bureau of the Township. Such appeal shall be taken within thirty (30) days of entry of the decision in Township records, by filing with the Board of Appeals a notice of appeals specifying the grounds thereof.
  
  - ii. *Hearing and notice.* Appeals and variance requests shall be heard within forty five (45) days after receipt, at a public hearing, notice of which is to be published once at least ten (10) days prior to the hearing in a newspaper, setting forth the time, date, place and reason for the hearing. Property owners and occupants of the Township record within three hundred (300) feet in all directions of the affected property shall have a notice

sent them by first class mail, at the address given in the last assessment roll. A decision shall be made within thirty (30) days, in writing, setting forth reasons if the appeal or variance is rejected.

- iii. All decisions by the Board of Appeals in granting variances or in hearing appeals shall be final, except that any affected person or persons, or any department, board or commission, or the state with an interest affected shall have the right to appeal within thirty (30) days after the decision, to the Circuit Court in the County in which the land is located on questions of law and fact. For purposes of determining who constitutes a person with an “interest affected”, it shall be deemed to include an applicant, the municipal body or a subdivision of the same, a person who resides within three hundred (300) feet or a person who appeared at the hearing and spoke in opposition to the position taken by the Board of Appeals.

## **ARTICLE 21**

### **110.2100 AMENDMENTS**

#### **110.2101 Governing provisions.**

Sec. 21.01. The regulations, restrictions and boundaries set forth in the Ordinance may be amended, supplemented or repealed in accordance with the provisions of this Article.

#### **110.2102 Initiation.**

Sec. 21.02. Amendments to the Zoning District Map may be initiated by Township Board, Zoning Administrator or Planning Commission on any parcel located within the Township. A person owning property may file a petition to amend the zoning classification affecting his/her property.

#### **110.2103 Referral to Planning Commission.**

Sec. 21.03. Amendments shall be referred to the Planning Commission for study and report and may not be acted upon by the Township Board until it has received the recommendation of the Planning Commission on the proposed amendment, or until sixty (60) days have elapsed from the date of reference of the amendment with a report being prepared by the Planning Commission. Upon receipt of the report and recommendation of the Planning Commission, or after sixty (60) days have passed without a

recommendation from the Planning Commission, the Township Board, by a majority vote, may adopt in whole or in part, deny or take any other action on the proposed amendment as it may deem advisable. Changes and amendments hereunder shall become effective immediately after passage by the Township Board, subject to statutory requirements.

**110.2104 Filing; publication.**

Sec. 21.04. Amendments shall be filed with the Township Clerk, and one (1) notice of the adoption and summary of the amendment shall be published in a newspaper of general circulation in the Township within fifteen (15) days after adoption. Said notice shall provide either a summary of the regulatory effect, or the text of the amendment.

**110.2105 Hearing.**

Sec. 21.05.

- a. No amendment shall be adopted until a public hearing has been held thereon by the Planning Commission.
- b. If an individual property or several adjacent properties are part of the proposed amendment, notice of the public hearing shall be given to the owner of the property in question, to all persons to whom any real property within three hundred (300) feet of the premises in question is assessed, and to the occupants of all single and two-family dwellings within three hundred (300) feet (excluding public lands). The notice shall be delivered personally or by mail to the respective owners and tenants at the address given in the last assessment roll. The notice shall be made not less than eight (8) days before the hearing and state the time, place and purpose of the hearing.
- c. No action shall be taken on any application for an amendment by the Planning Commission or the Township Board until the applicant shall have paid an appropriate filing fee as established by the Township Board in its Schedule of Fees.

## **ARTICLE 22**

### **110.2200 FEES, CHARGES, AND EXPENSES**

#### **110.2201 Schedule of fees.**

Sec. 22.01. The Zoning Administrator shall recommend a schedule of fees, charges and expenses for permits, certificates, appeals, hearings, special meetings and other documents and actions required by the provisions of this Ordinance to be adopted by resolution of the Township Board. This schedule shall be available to the public from the Township Clerk and from the Zoning Administrator. No permit, certificate or variance shall be issued unless such fees, charges or expenses have been paid in full, nor shall any action be taken on proceedings before the Board of Appeals or Zoning Board, unless or until fees, charges and expenses have been paid in full.

## **ARTICLE 23**

### **110.2300 VIOLATIONS AND PENALTIES**

#### **110.2301 General.**

Sec. 23.01. Uses of land and dwellings, buildings or structures including tents and trailer coaches, used, erected, altered, razed or converted in violation of this Zoning Ordinance are a nuisance per se.

#### **110.2302 Violation and penalty.**

Sec. 23.02. Any person, firm or corporation who violates, disobeys, omits, neglects, or refuses to comply with, or who resists the enforcement of any other provision of this Ordinance shall be guilty of a misdemeanor, and upon conviction thereof, shall be subject to a fine of not less than fifty (\$50.00) dollars, nor more than five hundred (\$500.00) dollars, and may be imprisoned in the County Jail for a term not to exceed ninety (90) days, or both. Each day that a violation is permitted to exist shall constitute a separate offense.

## **ARTICLE 24**

### **110.2400 SEVERABILITY**

Sec. 24.01. In any case in which the provisions of this Ordinance are declared by the courts to be unconstitutional or invalid, said ruling shall not affect the validity of the remaining provisions of the Ordinance and to this end the provisions of this Ordinance are declared to be severable.

## ARTICLE 25

### 110.2500 REPEAL OF CONFLICTING ORDINANCES

#### 110.2501 Repeal; adoption.

Sec. 25.01. Any Zoning Ordinance existing at the time of the effective date after adoption of this Zoning Ordinance, together with all amendments and supplements thereto, and all other ordinances adopted by the Township which are inconsistent with the provisions of this Ordinance are, to the extent of such inconsistency, and no further, hereby repealed.

Published: August 9, 1988

Effective: September 8, 1988